

OPERATIVE VERSION OF PLAN CHANGE 30A

**BEACHLANDS VILLAGE BUSINESS CENTRE ZONE
PRIVATE PLAN CHANGE NO. 30A
TO THE MANUKAU DISTRICT PLAN
PURSUANT TO THE FIRST SCHEDULE TO
THE RESOURCE MANAGEMENT ACT 1991
SCHEDULE**

1 AMEND

Amend Chapter 17 Table of Contents by adding the following heading:

17.17 BEACHLANDS VILLAGE BUSINESS CENTRE

2 AMEND

Amend Chapter 17 by inserting **17.17 BEACHLANDS VILLAGE BUSINESS CENTRE** as follows:

17.17 BEACHLANDS VILLAGE BUSINESS CENTRE

17.17.1 INTRODUCTION

Beachlands Village Business Centre

The existing Beachlands settlement is serviced by the existing business areas on Wakelin Road and Third View Avenue. These business areas function as small local service centres or local shopping areas. The business area on Third View Avenue is zoned Business 5 and therefore only provides for a limited range of retailing activity. The business area on Wakelin Road is zoned Business 1 but only has a limited amount of land available that has not already been fully developed for retail purposes.

Beachlands resident population has in the past been required to meet a significant proportion of its shopping and other commercial service needs outside of the Beachlands settlement (for instance at Howick and Botany). To a large extent this has been due to the limited range and scale of shops and services provided within the Beachlands settlement. This issue will become more acute with the residential growth resulting from the development of the Beachlands Village: New Avenues area. It is important that there is an adequate balance between local populations and the activities needed to service that population. The Beachlands Village: New Avenues Structure Plan has identified a new business area at the intersection of Beachlands Road and Whitford – Maraetai Road. This location has been identified as being appropriate as it is on a key transportation route, is central to both Beachlands and Maraetai and is not constrained by land availability issues. The existing business areas on Wakelin Road and Third View Avenue will continue to have an important role in servicing the established residential area of the Beachlands settlement.

It is important to ensure that the development form, look and feel of the business centre is sympathetic to character of the existing Beachlands settlement. Development within the business centre therefore needs to be designed specifically for the Beachlands community and setting.

17.17.2 RESOURCE MANAGEMENT ISSUES

Issue 17.17.2.1 The current range and scale of retail and commercial activities at Beachlands is limited and cannot develop in a way that can sustainably service the existing and growing community given the restricted opportunities for further development in the existing business zones. There is a need to ensure that provision is made for the development of a new business area for this community on a key transportation route consistent with the strategic criteria for growth in the region.

The strategic direction established for growth in the region highlights the need to manage growth in an integrated manner with the aim of consolidating development to a sustainable compact urban form, with well integrated land uses and transport networks. Existing shopping at Beachlands is limited in the range and scale of services offered. There is significant potential for further retail and commercial development to occur at Beachlands to provide for the wellbeing of this community.

It is important to allow for controlled and well planned provision for business growth to ensure that the existing and growing Beachlands community can sustainably cater for its current and future needs consistent with the wider regional direction for growth.

Issue 17.17.2.2 Residential development in the Beachlands Village: New Avenues area will create additional demand for business land.

The concerns identified in relation to the limited range and scale of retail and commercial activities at Beachlands will become more pressing with the strong residential growth expected from the development of the Beachlands Village: New Avenues area. To provide adequately for the wellbeing of this community there needs to be a corresponding increase in retail and commercial activity to avoid the need to access shops and other commercial activity outside of the Beachlands and Maraetai area.

The existing business areas on Wakelin Road and Third View Avenue are unable to develop in a way to sustain the existing and growing community given the constraints of the surrounding residential land and limited developable business zoned land. An area has been identified in Beachlands Village: New Avenues at the intersection of Beachlands Road and Whitford – Maraetai Road. This location is appropriate for the community as it is on the main transportation route, is central to both Beachlands and Maraetai and is not constrained by land availability issues. The existing business areas on Wakelin Road and Third View Avenue and Pine Harbour Marina will continue to have an important role in servicing the established residential area.

Issue 17.17.2.3 A standard suburban shopping centre design and layout may compromise the character of Beachlands as a rural and coastal settlement. Development in the Beachlands Village Business Centre should maintain the character of the existing and developing Beachlands settlement in a way that integrates with the surrounding rural and coastal context.

The existing Beachlands settlement sits between rural pasture and the coast presenting a distinctive rural/coastal residential character. The development of a standard suburban shopping centre may compromise this distinctive character. The development of the Beachlands Village Business Centre needs to be managed to respond to its context and to maintain the special qualities that Beachlands enjoys. These qualities include the intimate relationship of buildings with the street, the presence of open space with a substantial 'green' (planted) element and buildings that are designed to complement rather than dominate their surroundings. Given the nature and form of a retail and commercial use is considerably different to the residential and rural uses adjoining the Beachlands Village Business Centre, the design challenge will be that of interpretation, in particular, how the essential character qualities of the existing settlement can be interpreted in a design response that presents a modern quality business centre.

Issue 17.17.2.4 Development within the Beachlands Village Business Centre will need to be undertaken in a manner that provides for integration and connection with the established transportation network and the transportation network planned for the surrounding residential area, in particular the Beachlands Road and Whitford – Maraetai Road intersection.

Uncoordinated and inappropriately designed development within the Beachlands Village Business Centre has the potential to lead to the inefficient provision of roading improvements and connections to the existing and planned transportation network. The surrounding road network needs to safely and efficiently support development within the Beachlands Village Business

Centre. In addition the site accesses need to provide for and maintain safe and efficient movement of vehicles, public transport users, cyclists and pedestrians.

Issue 17.17.2.5 Development in the Beachlands Village Business Centre needs to ensure that the northern view shaft from the Whitford / Maraetai Road is appropriately considered.

The visual integrity and values of views towards the coast and gulf islands from the Whitford-Maraetai Road have the potential to be adversely affected by inappropriately located or inappropriately sized development. It is important to ensure that the northern views currently experienced from the Whitford / Maraetai Road view shaft are not compromised by the future development of the Beachlands Village Business Centre. Future development within the new business centre therefore needs to be designed appropriately to ensure that these views are maintained as far as practical.

Issue 17.17.2.6 The potential for adverse effects on amenity values and the quality of the environment of adjoining residential, rural and public open space areas as a result of nuisance elements such as noise, dust, odours and glare need to be appropriately managed while continuing to provide for the operational requirements of the retail and commercial activities carried out within the Beachlands Village Business Centre.

Retail and commercial activity in the Beachlands Village Business Centre has the potential to adversely affect amenity values and the quality of the environment in the adjoining residential, rural and public open space areas. The potential for adverse effects are mainly related to the creation of nuisance elements such as noise, vibration, dust, odours and glare. The scale and intensity of development, hours of operation and the amount of advertising can also conflict with surrounding residential activity and lead to the degradation of local amenity. The potential for adverse effects on adjoining residential, rural and public open space areas needs to be appropriately managed in a manner that continues to provide for the operational requirements of the retail and commercial uses.

Issue 17.17.2.7 Sufficient parking and loading facilities need to be provided for within the Beachlands Village Business Centre to ensure that the potential for impacts on the roading network and the local neighborhood are appropriately managed.

The parking and loading demands of retail and commercial development in the Beachlands Village Business Centre need to be adequately provided for to ensure that the potential for impacts on the surrounding neighbourhood and people's convenience are appropriately avoided or mitigated.

Issue 17.17.2.8 Development in the Beachlands Village Business Centre may affect the existing drainage patterns, create greater rates of stormwater runoff and affect the quality of stormwater.

The development of greenfield land for retail and commercial purposes in the Beachlands Village Business Centre will increase impermeable areas. Without proper treatment, stormwater discharges from roads, vehicle circulation areas and car parking areas may increase contaminant loads in local waterways and contribute to pollution in the sensitive coastal receiving environment, including the receiving environment at Pine Harbour Marina. The approval of a Network

Discharge Consent will set out the strategy and necessary works required for the management of stormwater within the Beachlands Village: New Avenues area.

Issue 17.17.2.9 Development in the Beachlands Village Business Centre will create demands on infrastructure.

Physical infrastructure includes the provision of water supply, wastewater, stormwater and solid waste disposal as well as communications and power. Uncoordinated and inappropriately designed development within the Beachlands Village Business Centre has the potential to lead to the inefficient provision of infrastructure such as the supply of potable water and connections to the existing wastewater network. The timing, provision and development of physical infrastructure are critical to the management of the overall effects on the environment associated with subdivision, use and development of land within the Beachlands Village Business Centre.

Issue 17.17.2.10 Development in the Beachlands Village Business Centre may result in sediment loss during earthworks that could have the potential to adversely impact on the continued effective and efficient operation of downstream stormwater management infrastructure.

The earthworks operations that will be required to provide for suitable building platforms for retail and commercial development within the Beachlands Village Business Centre have the potential to result in adverse impacts on the operation of the Formosa pond and Pine Harbour Marina located downstream from the proposed new business area. It is therefore important to ensure that appropriate sediment control facilities are established and maintained as part of all earthworks operations undertaken within the new business area.

17.17.3 OBJECTIVES

Objective 17.17.3.1 To provide for a village business centre at Beachlands in a location and at a scale that caters for the retail and commercial needs of the existing and future community.

(This objective relates to Issues 17.17.2.1 and 17.17.2.2)

Objective 17.17.3.2 To provide for retail and commercial development within the village business centre at Beachlands which is consistent with the wider direction for growth in the region and the needs of the catchment.

(This objective relates to Issue 17.17.2.1)

Objective 17.17.3.3 To provide for a village business centre at Beachlands within which the form, look and feel of development is managed to ensure a development outcome which responds to its open, outdoors orientated character, rural and coastal context and maintains the qualities of the existing Beachlands settlement.

(This objective relates to Issues 17.17.2.3 and 17.17.2.4)

Objective 17.17.3.4 To provide for a built form within the Beachlands Village Business Centre which ensures that the northern view shaft from the Whitford / Maraetai Road is reasonably maintained.

(This objective relates to Issue 17.17.2.5)

Objective 17.17.3.5 To maintain the amenity values of residential, rural and public open space areas from the potential for adverse effects of retail and commercial activities within the Beachlands Village Business Centre having regard to the operational requirements of the business environment.

(This objective relates to Issue 17.17.2.6)

Objective 17.17.3.6 To provide for the safe and convenient movement of people and goods within the Beachlands Village Business Centre and ensure that the Centre is well integrated and connected with the existing and planned transportation networks.

(This objective relates to Issues 17.17.2.4 and 17.12.2.7)

Objective 17.17.3.7 To provide for the management of stormwater within the Beachlands Village Business Centre in accordance with the strategy for the management of stormwater set out in the Network Discharge Consent for the Beachlands Village: New Avenues area.

(This objective relates to Issues 17.17.2.8 and 17.17.2.9)

Objective 17.17.3.8 To ensure the efficient and effective provision of infrastructure to the Beachlands Village Business Centre including road, cycle and pedestrian networks, connection to the existing wastewater network, supply of potable water, treatment and disposal of stormwater and telecommunications and power supply facilities.

(This objective relates to Issues 17.17.2.4, 17.17.2.7 and 17.17.2.9)

Objective 17.17.3.9 To provide for the effective management of earthworks operations during both the bulk earthworks phase of development and the subsequent building construction phase of development through the use of appropriate sediment control measures.

(This objective relates to Issue 17.17.2.10)

17.17.4 POLICIES

Policy 17.17.4.1 The development of a new business area shall be provided for at Beachlands through the creation of the Beachlands Village Business Centre Zone over the land located adjacent to the intersection of Beachlands Road and Whitford – Maraetai Road.

Explanation/Reasons

This policy seeks to achieve Objectives 17.17.3.1 and 17.17.3.2.

The land located at the intersection of Beachlands Road and Whitford – Maraetai Road has been identified for development to meet the retail and commercial needs of the growing Beachlands community as it is on a main transport route, is central to both Beachlands and Maraetai and is not constrained by land availability issues. The creation of a specific zone over this land is the most appropriate method to provide for the development of a new business area at this location that can sustainably cater for the future retail and commercial needs of the growing Beachlands community. The provision of the Beachlands Village Business Centre Zone will reduce the prospect of resource consent applications being made for ad hoc retail and commercial development that may be difficult to decline in the absence of sufficient provision for such activities being made in the Beachlands settlement.

Methods

- Zoning
- Rules
- Concept Plan

Policy 17.17.4.2 **The Beachlands Village Business Centre Zone shall enable a wide range of retail and commercial activities in order to service the needs of the existing and growing community, in particular through providing for:**

- **One supermarket of up to 4,000m² GFA (excluding loading areas);**
- **A service station;**
- **Convenience shops;**
- **Entertainment facilities and cinemas;**
- **Commercial services;**
- **Offices;**
- **Hotels, motels and travelers accommodation;**
- **Garden centres;**
- **Building improvement centres;**
- **Community and healthcare services and facilities and medical centres;**
- **Community buildings and facilities;**
- **Care centres, pre-school centres and educational facilities;**

- **Cafes, restaurants and takeaway food premises;**
- **Taverns;**
- **Retail sales, retail activities, shops and stalls; and**
- **Associated parking, loading and access;**

Explanation/Reasons

This policy seeks to achieve Objectives 17.17.3.1 and 17.17.3.2.

The Beachlands Village Business Centre needs to provide for a wide range of retail and commercial activities to enable the community to be able to sustainably cater for its current and future needs. The key facilities that will contribute to the success of the business centre will be the presence of a supermarket and service station. The supermarket provides the anchor store which ensures the attraction of large numbers of customers while the service station provides the convenience and assurance of access (mobility). Through the provision of a wide range of other retail and commercial activities to support the supermarket and service station such as a hotel and restaurants and cafes the current and future needs of the community can be sustained over time thereby ensuring that the development within the Beachlands Village Business Centre is economically viable.

Methods

- Zoning
- Rules

Policy 17.17.4.3 **Development outcomes within the Beachlands Village Centre Zone will be controlled in order to maintain and enhance the character and amenity associated with the new business area through the use of a Concept Plan, a Landscape Design Framework, Rules and Assessment Criteria based on established urban design, landscape design and sustainable management principles that:**

- **Encourage a sense of place and identity;**
- **Compliment the character of the Beachlands settlement and surrounding area;**
- **Provide a high degree of connectivity and legibility through a well connected grid-pattern road network based on perimeter block designs and a legible pedestrian network;**
- **Avoids the development of internal malls;**
- **Relate to streetscapes so as to enhance perceptions of safety;**
- **Provide for streetscapes of high pedestrian amenity through active frontages creating a vibrant public realm; and**

- **Achieve a safe environment through consideration of Crime Prevention Through Environmental Design (CPTED).**

Explanation/Reasons

This policy seeks to achieve Objectives 17.17.3.3, 17.17.3.4, and 17.17.2.5.

The use of good urban design, landscape design and sustainable management principles will ensure the development of a successful built environment which will be both robust and responsive to the needs of the local community and the regional growth strategy. In particular, the sense of place that the Beachlands settlement emanates is distinctive and valued by the community. Development proposals need to consider this aspect to ensure that the proposal responds in a sympathetic manner. Some shopping forms such as malls are not appropriate in this rural and coastal village environment. A business centre which provides a well connected and legible urban network will provide the fundamental step in creating a high quality pedestrian environment which encourages people to walk. This will be further enhanced by streetscapes which provide a good level of passive surveillance creating an environment which both feels safe and is safe. Landscape design will be guided by the Landscape Design Framework. All landscape design proposals in relation to the roads, at grade car parking areas and open space areas will be required to achieve consistency with the Landscape Design Framework.

Methods

- Zoning
- Rules
- Concept Plan
- Landscape Design Framework
- Development and Performance Standards
- Assessment Criteria

Policy 17.17.4.4 The height of buildings within the Beachlands Village Business Centre Zone that are located within the northern view shaft from the Whitford-Maraetai Road shall be controlled through the use of an appropriate height restriction that ensures the views to the coast and gulf islands are reasonably maintained.

Explanation/Reasons

This policy seeks to achieve Objective 17.17.3.4.

There is potential for development within the Beachlands Village Business Centre Zone to adversely affect the visual integrity and values of northern views towards the coast and gulf islands from the Whitford-Maraetai Road. These views could be adversely affected by such factors as inappropriately located buildings, the scale and intensity of activity and building heights intruding into the view shaft. The Beachlands Village Business Centre Zone will include development and performance standards to ensure that the integrity of the northern views shaft will not be adversely affected.

Methods

- Zoning
- Rules
- Concept Plan
- Development and Performance Standards

Policy 17.17.4.5 **Activities within the Beachlands Village Business Centre Zone adjoining residential, rural or open space areas shall be sited and designed in a manner that provides for the operational requirements of retail and commercial uses while avoiding, remedying and mitigating adverse effects on visual amenity; privacy; the acoustic environment; air quality; pedestrian and vehicle safety; and other associated attributes of neighbouring residential, rural and public open space areas.**

Explanation/Reasons

This policy seeks to achieve Objective 17.17.3.5.

There is potential for activities within the Beachlands Village Business Centre Zone to have adverse effects on the amenity values of residential, rural and public open space areas. The amenity values of adjoining activities could be adversely affected by such factors as the scale and intensity of activity, the design and external appearance of buildings, traffic generation, vehicle access, hours of operation, noise, parking, glare and vibration. The Beachlands Village Centre Zone will include development and performance standards to ensure that the amenity values of neighbouring activities will not be adversely affected.

Methods

- Zoning
- Rules
- Concept Plan
- Landscape Design Framework
- Development and Performance Standards

Policy 17.17.4.6 **Development in the Beachlands Village Business Centre shall ensure that attention is given to the provision of an integrated transport system that provides for:**

- **Good connectivity with the existing and planned road networks;**
- **Efficient and safe networks for cars, public transport, cyclists and pedestrians;**

- **Safe vehicular and / or pedestrian access from a legal road to all retail and commercial premises; and**
- **Adequate provision for the parking and loading of vehicles including the use of shared parking and loading facilities and on street parking.**

Explanation/Reasons

This policy seeks to achieve Objectives 17.17.3.6 and 17.17.3.8.

An integrated transport system requires a well-connected roading pattern. It also requires consideration at the design stage for provision to be made for the movement of goods, private vehicles, public transport, cyclists and pedestrians. The Beachlands Village Business Centre Concept Plan will detail the connections to the existing and planned road networks, the key access points to the business centre and the areas identified for parking and loading. This will ensure that development within the business centre is based on an integrated transportation design approach. The provision of safe and efficient access and parking and loading areas will continue to be controlled through the development and performance standards contained in Chapter 8 – Transportation. However, the mixed use nature of the Beachlands Village Business Centre means that the use of shared parking and loading facilities and on street parking is appropriate and may justify a relaxation of the parking and loading provisions. The provision of shared parking and loading facilities and on street parking will therefore be encouraged in the Beachlands Village Business Centre where appropriate to support an integrated parking and loading solution, which ensures that space is used effectively.

Methods

- Zoning
- Rules
- Concept Plan
- Development and Performance Standards

Policy 17.17.4.7 The Beachlands Village Business Centre shall be developed and activities sited, designed and operated so as to avoid discharges which would have adverse effects on the quality of water through the provision of stormwater infrastructure consistent with the strategy for the management of stormwater set out in the Network Discharge Consent for the Beachlands Village: New Avenues area.

Explanation/Reasons

This policy seeks to achieve Objectives 17.17.3.7.

The stormwater discharges from roads, vehicle circulation areas and car parking areas located within the Beachlands Village Business Centre has the potential to degrade water quality and it's associated intrinsic and habitat values through increased contaminant loads to sensitive receiving environments. The management of stormwater discharges in accordance with the strategy set

out in Network Discharge Consent for the Beachlands Village: New Avenues area will ensure that any potential adverse effects are avoided or mitigated.

Methods

- Zoning
- Rules
- Development and Performance Standards

Policy 17.17.4.8 **Development within the Beachlands Village Business Centre shall ensure that provision is made for environmentally appropriate infrastructure including reticulated infrastructure for wastewater disposal, stormwater collection, treatment and disposal facilities, adequate on site and / or off site infrastructure for the supply of potable water and telecommunications and power supply facilities.**

Explanation/Reasons

This policy seeks to achieve Objectives 17.17.3.7 and 17.17.3.8.

To ensure that the Beachlands Village Business Centre Zone can accommodate the retail and commercial activities provided for within this zone in an environmentally appropriate manner it is necessary to ensure that all activities can be appropriately serviced for wastewater, stormwater, water supply, communications and power supply.

Methods

- Zoning
- Rules
- Development and Performance Standards
- Building Act 1991

Policy 17.17.4.9 **Development within the Beachlands Village Business Centre shall ensure that provision is made for the establishment and maintenance of sediment control facilities that meet the requirements of Auckland Regional Council’s Technical Publication No. 90 during both the bulk earthworks phase of development and the subsequent building construction phase of development until the entire catchment site is fully stabilised and / or developed.**

Explanation/Reasons

This policy seeks to achieve Objectives 17.17.3.9.

To ensure that the earthworks undertaken within the Beachlands Village Business Centre Zone does not adversely impact on the continued operation of downstream stormwater management infrastructure, in particular the existing Formosa pond, all earthworks operations that exceed the

maximum limits provided for in the Rule 9.8.2 will be required to demonstrate how provision has been made for the establishment and maintenance of appropriate sediment control measures. The provision of sediment control facilities in accordance with the requirements of Auckland Regional Council's Technical Publication No. 90 will be deemed to be appropriate measures to meet this requirement. Where possible, any stormwater treatment ponds and / or wetlands that are utilised as sediment control facilities should only be converted to a stormwater treatment pond and / or wetland once all construction works have been completed.

Methods

- Rules
- Assessment Criteria
- Regional Plans

17.17.5 STRATEGY FOR BEACHLANDS VILLAGE BUSINESS CENTRE

The strategy for the Beachlands Village Business Centre summarises the overall approach to managing the natural and physical resources in and surrounding this business area in order to promote sustainable management. The strategy results from the objectives and policies for the Beachlands Village Business Centre Zone and relates, in particular, to the need for increased retail and commercial services at Beachlands to provide for the social, economic and cultural wellbeing and health and safety of this growing community.

Business centres are important facilities for providing retail and community services to the community. The District Plan recognises that there are significant community and resource management benefits to be gained by preventing the dispersal of pedestrian oriented and high traffic generating retail and commercial activities and therefore guides the location of such activities towards integrated centres.

The Beachlands Village Business Centre Zone provides for an integrated centre to be established at Beachlands. The zone seeks to promote the development of a high quality business centre in a strategic location to a community that is in need of additional and improved retail and commercial facilities. To ensure the form, look and feel of the existing Beachlands settlement is retained the zone encourages a design response that sensitively considers the character of the existing settlement and the surrounding environment.

The roundabout on Whitford-Maraetai Road acts as a gateway to the Beachlands settlement and is the logical place to locate the Beachlands Village Business Centre Zone. The location of the business centre on this key transportation route means the facilities can serve the communities of both Beachlands and Maraetai. This area also integrates well with the new Beachlands Village: New Avenues residential area.

At present Beachlands is a residential settlement next to the coast. This form of development is not sustainable in that people regularly travel by car to go to work and to buy the goods and access the services they need. The strategy for the Beachlands Village Business Zone is

therefore focused on the creation of a business centre that can sustainably service the retail needs of this growing community. The zone does make provision for the establishment of community facilities within the business centre. However, the existing facilities located within the business areas on Wakelin Road and Third View Avenue will continue to have an important role in servicing the established residential area, and the intention is not to diminish the local shops role that the Wakelin Road area is zoned for.

The provision of the Beachlands Village Business Centre will improve the sustainability of the settlement as it grows over time. The business centre will offer the basic facilities that are needed by the community such as food, petrol, financial, clothing and medical services at a location considerably closer than the current major shopping destinations. The business centre, while not providing the same level of work opportunities as an office or industrial use, will also provide a good number of varied jobs.

The Beachlands Village Business Centre will also improve the quality of choice that the settlement offers its community. The settlement currently offers very few other facilities to its community. It has become in effect a commuter satellite, where people travel to do their shopping or to go to work, because those facilities are not available within the settlement.

An important consideration of the strategy is the ongoing viability of the Beachlands Village Business Centre Zone. Empty shops and deserted car parks will not promote an attractive business environment or contribute to the amenity of the centre. It is therefore critical that development within the zone is economically viable and sustainable. The key use factors that can be attributed to the success of the business centre are the presence of a supermarket and a service station. The supermarket provides the anchor store which ensures the attraction of large numbers of customers, while the service station provides the convenience and assurance of access. The strategy for the zone is to provide for both a large supermarket and a service station.

The aim of the Beachlands Village Business Centre Zone is to create a business centre which is locally distinctive and reinforces the character of the existing settlement. Some forms of business centres, such as internally-orientated malls, are inappropriate to the local rural and coastal village character. The strategy for the zone seeks to ensure that development proposals take appropriate account of the distinctive qualities of the surrounding environment and the character of the existing settlement. The zone therefore seeks to avoid development which creates a sense that the buildings could be placed anywhere because they have no particular relationship with their surroundings.

The zone has recognised that the environment of the Beachlands Village Business Centre will be considerably different to the residential environment of the existing Beachlands settlement, but seeks to encourage design that responds to the existing character of the Beachlands settlement while still providing for a modern, quality form of retail and commercial development.

17.17.6 IMPLEMENTATION

17.17.6.1 Regulatory Methods

17.17.6.1.1 Beachlands Village Business Centre Zone

The Beachlands Village Business Centre Zone has been formulated to give effect to the policies for this special zone. The Beachlands Village Business Centre Zone is a standalone business

zoning that has been advanced to promote the adoption of a design-led approach for development within this area to ensure that the form, look and feel of this development is sympathetic to the character of the Beachlands settlement.

The Beachlands Village Business Centre Zone has some similarities to the Business 2 (Suburban Centres) Zone in that it applies to a medium sized shopping centre. Consistent with the Business 2 (Suburban Centres) Zones dispersed throughout the residential areas of the District the Beachlands Village Business Centre Zone is a short vehicle trip away for most residents of this settlement. The zone is also located on the primary transportation routes of Whitford-Maraetai Road and Beachlands Road and can act as a hub for passenger transport. Being located adjacent to the Whitford-Maraetai Road and Beachlands Road roundabout and within the Beachlands Village New Avenues growth area means the zone is readily accessible by the residents of both Beachlands and Maraetai.

The Beachlands Village Business Centre Zone is distinguished by methods that are designed to achieve an acceptable level of effects on the surrounding environment in respect of matters such as character, streetscape typology, visual amenity, landscaping, screening, scale and intensity of development, noise levels within the zone and noise levels at the boundary with residential activities and traffic generation and parking.

The Beachlands Village Business Centre involves the integrated development of retail and commercial activities and other services and facilities including community facilities. The range of activities permitted or controlled in the zone is broad in order to promote the minimisation of vehicle trip generation, duration and length and to encourage the development of a vibrant and successful built business environment, which is both robust and responsive to the needs of the local community and the catchment area. Activities which have the potential to have adverse effects on the amenity values of the business area, or the environmental quality of the surrounding residential area, are discretionary or non complying.

The size and shape of the Beachlands Village Business Centre Zone reflects the need to provide for sustainable retail and commercial expansion over the long term consistent with the growth in population expected in the primary and secondary catchments. The size and shape of the zone will ensure that business growth is not constrained by land availability, and that the potential for adverse effects on neighboring residential areas of business activity within the zone are avoided, remedied or mitigated. In particular the zone will be separated from the adjoining residential areas by roads. This separation avoids much of the potential for business activities to adversely affect the residential environment.

The location of the Beachlands Village Business Centre on primary roads also means that the intensity of activity, particularly in terms of traffic generation, can be accommodated with only minor effects on traffic safety and efficiency. The management of the effects that may be attributed to parking and loading within the zone will be achieved through the existing transportation provisions. However, shared parking and loading facilities and on street parking will be encouraged to provide for an integrated outcome.

A high standard of amenity is to be maintained and enhanced within the Beachlands Village Business Centre. The integration of new development within the zone is important in this respect, and will be achieved by a requirement for controlled activity resource consent for all new buildings and external alterations to existing buildings. Controlled activity resource consents for roads, at grade parking areas and open space areas will also be required, with the matters for control

restricted to visual amenity values, streetscape character, the extent, type and nature of landscaping and the maintenance of plantings. This will ensure that the form, look and feel of development within the zone is controlled to achieve a development outcome which responds in a sympathetic manner to the existing Beachlands settlement.

17.17.6.1.2 Beachlands Village Business Centre Concept Plan

The Beachlands Village Business Centre Concept Plan sets a number of fundamental parameters for the design outcome desired for this business area. The Concept Plan locates where the streets (including access points) and perimeter building blocks are to go, where buildings are indicatively allowed for and in particular where the supermarket (the anchor store) is to be placed. Other areas are indicated and identified uses are established such as open space plazas and parking and loading areas. The important urban design aspects of active street frontages are established within the Concept Plan and a number of landmark corners are identified. The Concept Plan provides a clear framework for the development of the Beachlands Village Business Centre. It is not intended to be prescriptive in terms of detail. The detail contained within the Concept Plan may be amended when later detailed planning is undertaken. However the basic structure of roading and block patterns and the position of open space, open space plazas and major activities is expected to be in accordance with the Concept Plan, and may only be departed from through Discretionary Activity resource consent processes.

17.17.6.1.3 Beachlands Village Business Centre Landscape Design Framework

The Beachlands Village Business Centre Landscape Design Framework sets the parameters for the integrated landscape design outcome that is sought within the business area. The Landscape Design Framework outlines the landscape design requirements for the street, at grade car parking and open space environments within the zone. Indicative typologies for the streets, at grade car parking areas, open space areas and plazas are detailed to give an indication of the form, scale, variation and integration required in the landscape response. The landscape philosophy represented in the Landscape Design Framework seeks to integrate development into the surrounding landscape setting where possible, mitigate any adverse visual or landscape effects of development, strengthen and reinforce the existing pattern and character of the settlement, maintain the landscape character and rural / coastal amenities, achieve a high level of amenity within the business centre and create high quality streetscapes and open space areas. The Landscape Design Framework is indicative only and is intended to lead design proposals rather than provide a detailed landscape design format. As such the Landscape Design Framework is not to scale and development proposals will be considered in terms of whether they meet the general intent of the framework rather than any particular specifics.

17.17.6.1.4 Activity Types

Permitted activities within the zone are those which, provided they comply with the specified development and performance standards are considered unlikely to generate adverse effects on the environment. A wide range of retail and commercial activities are listed as Permitted Activities in the Beachlands Village Centre Business Zone.

Controlled Activities are those which are unlikely to generate adverse effects but which may have particular elements which require the Council to exercise its discretion over the activity through the implementation of appropriate conditions. For example, this status is applied to buildings to ensure consistent design outcomes are achieved where matters assessed are design and

external appearance, site layout, pedestrian amenity and access, car parking and overall consistency with the assessment criteria. This status is also applied to roads, at grade car parking areas and open space areas to ensure that the integrated landscape design outcome developed for the business centre can be achieved.

Restricted Discretionary Activities are those which may be appropriate in the zone but comprise elements which may generate adverse effects which need to be addressed through the application of conditions or refusal of consent. For example, activities that do not comply with any or all of the development and performance standards can generate adverse effects such as traffic and the need for parking or visual impacts of building developments. This status will enable the effects to be assessed and appropriate controls put in place.

Discretionary Activities are those which may be appropriate in the zone but have the potential to result in adverse effects on the environment. For example, any activity that is not located as provided in general accordance with the Beachlands Village Business Centre Concept Plan is a Discretionary Activity because of the wide range of potential adverse effects that could occur if the planned form of development for the zone is not implemented such as traffic effects, insufficient parking provision, visual effects, character and amenity impacts and activity integration effects.

Non Complying Activities are those activities that the Council does not anticipate will occur in the zone, but may be appropriate in circumstances where the relevant statutory tests are met. Any activity that is not provided for as a Permitted, Controlled, Restricted Discretionary or Discretionary in the zone is considered to be a Non Complying Activity.

17.12.6.1.5 Development and Performance Standards

Development and performance standards are the rules which apply to the development of buildings and structures and establishment of activities in the Beachlands Village Business Zone as Permitted or Controlled Activities. The development and performance standards are intended to ensure that activities in the Beachlands Village Centre Zone achieve a high level of amenity sympathetic to the character of the Beachlands settlement.

It is also intended that that development in the Beachlands Village Centre Business Zone adjacent to residential and public open space zones be compatible with the amenity values of those areas. The buildings established in the business centre will often be larger in scale than residential buildings and could visually dominate and overshadow them impacting on neighbourhood amenity values. The development and performance standards are also intended to control the impact of nuisance elements such as noise, vibration, dust and glare at the zone interface.

17.12.6.1.6 Matters for Control and Matters for Discretion and Assessment Criteria

Controlled Activities are subject to rules that specify the matters for control. Resource consent applications for a Controlled Activity are considered against the assessment criteria which relate to those matters. Similarly, Discretionary Activities over which the Council has restricted the matters for its discretion (Restricted Discretionary Activities) are assessed against the matters for discretion and the assessment criteria set out in this chapter. The matters for control and matters for discretion and the associated assessment criteria are intended to address the potential adverse effects of the activities listed as Controlled or Restricted Discretionary.

17.17.6.2 Non Regulatory Methods

Non District Plan methods that can assist to achieve the objectives and policies for the Beachlands Village Business Centre Zone include:

- The development of design guidelines to provide guidance for the design and external appearance of buildings and the relationships between car parking areas, landscaping and buildings, including the design of safer environments and the design of public spaces at a human scale.
- The design and implementation of physical works and services by the Council within the business centre to maintain and enhance amenity values of public space and to provide safe and efficient access by a variety of transport modes to the business centre.
- The establishment of community facilities within the business centre by the Council through the capital works programme including possible library, service centre, public open spaces and facilities within the public open spaces.
- The promotion and facilitation by the Council and other agencies of activities, events and initiatives within the business centre.

17.17.7 ANTICIPATED ENVIRONMENTAL RESULTS

From the identification of the resource management issues for activities in the Beachlands Village Business Centre Zone and the objectives, policies and rules for the Beachlands Village Business Centre Zone the expected environmental results can be identified. These include the following:

- Provision of a business centre of sufficient size which along with other existing business zones provides for the shopping and commercial activity needs of the Beachlands / Maraetai area.
- A configuration of streets and building layout, together with landscape and architectural design that responds to the existing character of the Beachlands settlement in a sympathetic and integrated manner while still adequately providing for the nature of the retail and commercial use
- The amenity in the residential and open space areas located adjacent to the Beachlands Village Business Centre Zone is maintained, in particular in relation to noise, vibration, odours, glare and visual amenity.
- The business centre achieves a high level of integration and connection with the existing and planned transportation networks.
- High quality streetscapes and public open spaces in the Beachlands Village Business Centre Zone.
- The quality and quantity of water in streams, ponds and wetlands adjacent the Beachlands Village Business Centre Zone is maintained and enhanced.
- Retail and commercial activities are adequately serviced for wastewater, water supply, stormwater, communications and power supply.

17.17.8 PROCEDURES FOR MONITORING

In order to assess the suitability and effectiveness of the objectives, policies and methods in achieving the anticipated environmental results for the Beachlands Village Business Centre Zone the Council intends to develop a monitoring programme (see Chapter 1, Section 1.7.3) which may include the following:

- Survey of activities in the Beachlands Village Business Centre Zone.
- Monitoring of complaints and enforcement actions regarding nuisance aspects of activities in the Beachlands Village Business Centre Zone.
- Monitoring of resource consents in the Beachlands Village Business Centre Zone including the number of applications granted resource consent, compliance with resource consent conditions and the effectiveness of those conditions.
- Monitoring of plan changes initiated in the Beachlands Village: New Avenues area.
- Survey of the community's satisfaction with amenity, safety and public facilities in the Beachlands Village Business Centre Zone.

17.17.9 RULES - ACTIVITIES

Rule 17.17.9.1 Activities in Beachlands Village Business Centre Zone

All activities in the Beachlands Village Business Centre Zone shall comply with the following:

- (a) All Permitted Activities in Rule 17.17.9.2 Activity Table shall comply with Rule 17.17.10 General Development and Performance Standards with the exception of Rule 17.17.10.3 – Landscaping.
- (b) All Controlled Activities in Rule 17.17.9.2 Activity Table shall comply with Rule 17.17.10 General Development and Performance Standards and Council shall exercise control over those matters specified in Rule 17.17.11 except that Rule 17.17.10.3 – Landscaping shall only apply to the construction or reconstruction and / or formation or reformation of roads, at grade car parking areas and open space areas.
- (c) For all Restricted Discretionary Activities in Rule 17.17.9.2 Activity Table Council shall exercise control over those matters specified in Rule 17.17.12.
- (d) All Discretionary Activities shall be assessed against Rule 17.17.13 Assessment Criteria – Discretionary Activities.
- (e) Any activity not listed in Rule 17.17.9.2 Activity Table is deemed to be a Non Complying Activity.
- (f) All Controlled Activities and Restricted Discretionary Activities in Rule 17.17.9.2 Activity Table shall be considered without the need for written approvals from affected persons and shall be considered without the need for limited notification or public notification, unless special circumstances exist.

Rule 17.17.9.2 Activity Table

In the Activity Table below the terms have the following meanings:

P = Permitted Activity

C = Controlled Activity

RD = Restricted Discretionary Activity

D = Discretionary Activity

N/C = Non Complying Activity

ACTIVITY	BEACHLANDS VILLAGE BUSINESS CENTRE ZONE
Any road or activity specified in Rule 17.17.9.2 that is not located and provided in general accordance with the Beachlands Village Business Centre Concept Plan contained in Beachlands Village Business Centre Appendix 1: Concept Plan.	D
Any activity specified in Rule 17.17.9.2 that does not comply with any or all of the Rules – Development and Performance Standards 17.17.10.1, 17.17.10.2, 17.17.10.4 to 17.17.10.7, 17.17.10.13, 17.17.10.14, and 17.17.10.17(b)	RD
Any activity specified in Rule 17.17.9.2 that does not comply with any or all of the Rules – Development and Performance Standards and is not provided for as a Controlled or Restricted Discretionary Activity.	D
The construction, erection or relocation of any building or external alterations or additions to any building	C
The construction or reconstruction and / or formation or reformation of roads, at grade car parking areas and open space areas.	C
Building Improvement Centres except in Stage 2 or Business Area A as shown on the Beachlands Village Business Centre Appendix 4: Staging Plan	P
Building Improvement Centres in Stage 2 as shown on the Beachlands Village Business Centre Appendix 4: Staging Plan	RD
Building Improvement Centres in Business Area A as shown on the Beachlands Village Business Centre Appendix 4: Staging Plan	N/C
Buildings and Facilities used for Educational, Recreational, Cultural, Social or Community Purposes	P
Cafes, Restaurants, Takeaway Food Premises and Tearooms except in Stage 2 as shown on the Beachlands Village Business Centre Appendix 4: Staging Plan	P
Cafes, Restaurants, Takeaway Food Premises and Tearooms in Stage 2 as shown on the Beachlands Village Business Centre Appendix 4: Staging Plan	RD
Buildings Ancillary to a Permitted Activity	P
Care Centres and Pre School / Educational Facilities	P
Churches	P
Citizen's Advice Bureau	P
Commercial Services	P
Community and Healthcare Services and Facilities and Medical	P

Services Premises	
Community Buildings and Facilities	P
Conference Facilities	P
Convenience Shops except in Business Area A or Stage 2 as shown on the Beachlands Village Business Centre Appendix 4: Staging Plan	P
Convenience Shops in Business Area A or Stage 2 as shown on the Beachlands Village Business Centre Appendix 4: Staging Plan	RD
Entertainment Facilities	P
Environment Centres / Information Centres	P
Garden Centres except in Stage 2 as shown on the Beachlands Village Business Centre Appendix 4: Staging Plan	P
Garden Centres in Stage 2 as shown on the Beachlands Village Business Centre Appendix 4: Staging Plan	RD
Hotels	P
Household Units	RD
Markets	P
Motels and Travelers Accommodation	P
Offices	P
Park and Ride Facilities and Related Activities	P
Residential Centres and Hostels	RD
Retail Sales, Retail Activities, Shops and Stalls except in Business Area A or Stage 2 as shown on the Beachlands Village Business Centre Appendix 4: Staging Plan	P
Retail Sales, Retail Activities, Shops and Stalls in Business Area A or Stage 2 as shown on the Beachlands Village Business Centre Appendix 4: Staging Plan	RD
Service Stations and All Associated Signage	C
Supermarket in the position shown on the Beachlands Village Business Centre Appendix 4: Staging Plan	P
Supermarket other than in the position shown on the Beachlands Village Business Centre Appendix 4: Staging Plan	N/C
Taverns except in Stage 2 as shown on the Beachlands Village Business Centre Appendix 4: Staging Plan	P
Taverns in Stage 2 as shown on the Beachlands Village Business Centre Appendix 4: Staging Plan	RD
Vehicle Access from Whitford-Maraetai Road other than that indicated on the Concept Plan	N/C
Network Utility Services	Refer to Rules Chapter 7 – Network Utility Services
Temporary Activities	Refer to Rules Chapter 5 – General Procedures and Rules
Activities which involve the Alteration, Destruction, Disturbance, Modification or Use of any Scheduled Heritage Resource	Refer to Rules Chapter 6 - Heritage
Relocated Buildings	Refer to Chapter 5 – General Procedures and Rules
Parking, Loading and Access	Refer to Chapter 8 - Transportation
Hazardous Facilities and Substances	Refer to Chapter 10.1 – Hazardous Facilities and Substances

Land Modification, Development and Subdivision	Refer to Rules Chapter 9 – Land Modification, Development and Subdivision
--	---

17.17.10 RULES – DEVELOPMENT AND PERFORMANCE STANDARDS

General Development and Performance Standards

Rule 17.17.10.1 Height

- (a) Height Area A (refer to Beachlands Village Business Centre Appendix 2: Height Areas):
 - (i) Maximum Height – No more than 2 storeys (excluding basements and basement car parks) with a maximum height of RL 47.00 above Mean Sea Level, Auckland Vertical Datum 1946.
 - (ii) Building Height in Relation to Boundary - Rule 5.18.1 contained in Chapter 5 - General Procedures and Rules shall not apply in the Beachlands Village Business Centre Zone except for the side and rear boundaries in Business Area A shown on the Beachlands Village Business Centre Concept Plan contained in Appendix 1.
- (b) Height Area B (refer to Beachlands Village Business Centre Appendix 2: Height Areas):
 - (i) Maximum Height – No more than 3 storeys (excluding basements and basement car parks) with a maximum height of RL 49.30 above Mean Sea Level, Auckland Vertical Datum 1946.
 - (ii) Building Height in Relation to Boundary - Rule 5.18.1 contained in Chapter 5 - General Procedures and Rules shall not apply in the Beachlands Village Business Centre Zone except for the side and rear boundaries in Business Area A shown on the Beachlands Village Business Centre Concept Plan contained in Appendix 1.
- (c) Notwithstanding the height requirements set out in Rule 17.17.10.1 (a) and (b) above, antennas on existing or proposed buildings are permitted provided they do not project more than 2 metres above the maximum permitted height of the building or structure for the zone and do not exceed 2 metres in any horizontal direction.

Explanation/Reasons

The maximum height controls will protect amenity values of adjoining areas from shading and the visual impact of building development, particularly buildings intruding into the northern view shaft from the Whitford-Maraetai Road.

Rule 17.17.10.2 Yards – Sites Within Business Area A

On sites located within Business Area A shown on the Beachlands Village Business Centre Concept Plan contained in Appendix 1 the following development and performance standards shall apply:

(a) Side Yards

- (i) 3 metres on each side or 6 metres on one side.
- (ii) A minimum of 50% of the area of the side yard, including a strip adjoining and parallel with the side boundary and having a minimum width of 2 metres, excluding any area required for vehicular and pedestrian access or any area adjoining the Landscape Buffer Area required along the Whitford-Maraetai Road (see Rule 17.17.10.3(b)), shall be landscaped, planted and maintained in trees, shrubs and grass to the satisfaction of Council at all times and in a manner as to create and preserve a good standard of amenity.

Explanation/Reasons

The provision of a Landscape Buffer Area (see Rule 17.17.10.3) and landscaped side and rear setbacks on those sites adjoining the Whitford-Maraetai Road will help to break and screen the visual density of retail and commercial buildings located within this area, particularly when viewed by people in the adjoining rural environment and by those entering Beachlands along the Whitford-Maraetai Road.

Rule 17.17.10.3 Landscaping

- (a) All roads, at grade car parking areas and open space areas (including plazas) shall be landscaped in general accordance with the Beachlands Village Business Centre Landscape Design Framework contained in Appendix 3.
- (b) The first stage of any development shall include the development of all of the 15 metre Landscape Buffer Area adjoining Whitford-Maraetai Road, and the Open Space Area adjoining Beachlands Road, as shown on the Beachlands Village Business Centre Concept Plan. The Landscape Buffer Area shall be developed to the following standards:
 - (i) All of that part of the site between the boundary with Whitford-Maraetai Road and a parallel line 15 metres therefrom which is not used for pedestrian access shall be planted in accordance with the Landscape Buffer Area Planting Plan and Planting Schedule (Landscape Design Framework 9 - Open Space - Whitford-Maraetai Road) contained in Beachlands Village Business Centre Appendix 3: Landscape Design Framework and secured by way of covenant or equivalent legal mechanism.
 - (ii) The developer shall be responsible for the maintenance of the Landscape Buffer Area, including weed control, mulching and watering and any necessary plant replacement, for a period of 2 years from the time of planting.

Note: Council may impose a bond to ensure compliance with (ii) above.

- (iii) Subject to the above requirements, the Landscape Buffer Area shall be vested in the Council free of charge at a time to be determined in the subdivision consent, being no more than 2 years after issue by the Council of the section 224(c) certificate under the Resource Management Act 1991.

Explanation/Reason

The provision of landscaping and open space will provide and maintain a high level of amenity within the Beachlands Village Business Centre. It will contribute to the character of the area and enhance the business area, and in particular the streetscapes. As well as a positive contribution to the amenity values of the Beachlands settlement and surrounding area, landscaping also provides a technique for mitigating potential adverse effects through the screening and softening of the appearance of buildings and car parking areas and provides for the design elements of form, scale and texture that complement development and open spaces.

Rule 17.17.10.4 Canopies and Verandas

All buildings with frontage to Active Street Frontage 1 on the Beachlands Village Business Centre Concept Plan contained in Appendix 1 shall be provided with a pedestrian canopy a minimum of 3 metres wide or 450mm in from the kerb edge.

Explanation/Reason

Pedestrian canopies and verandas improve the amenity for pedestrians encouraging people to walk. All development should give consideration to the continuity of canopies and where extensions to the provision would enhance the pedestrian route network this should be considered in the design process.

Rule 17.17.10.5 Active Street Frontage 1

All buildings with frontage to Active Street Frontage 1 on the Beachlands Village Business Centre Concept Plan contained in Appendix 1 shall be provided with a minimum of 65% glazing and shall include the main pedestrian access points out into the public realm.

Explanation/Reason

These frontages present the face of the business area and as such they need to provide a vibrant and attractive façade. The buildings along these frontages represent the most important building facades and as such should be interesting and well articulated creating a strong link through the use of glazing between the uses within the buildings and the street and public realm.

Rule 17.17.10.6 Active Street Frontage 2

All buildings with frontage to Active Street Frontage 2 on the Beachlands Village Business Centre Concept Plan contained in Appendix 1 shall be designed to face onto the street, provide the main entrance out to the public realm and provide a minimum of 40% glazing on the street frontage façade.

Explanation/Reason

These frontages are important in that they define the street edge and face to public areas and as such should provide a level of engagement with the public realm. The critical aspect is that these facades provide a good level of passive surveillance through the use of an appropriate amount of glazing to create a safe village centre environment.

Rule 17.17.10.7 Screening of Activities and Storage

Any outdoor storage or rubbish collection area visible from any residential, public open space or rural zone or from a public road or space shall be screened from public view by landscape planting and / or a 1.8 metre high close boarded fence and / or a 1.8 metre high solid wall.

Explanation/Reason

Suitable screening can reduce any unsightliness from storage and rubbish areas. Suitable screening can also mitigate the potential for effects associated with noise, dust and rubbish generated by retail and commercial activities.

Rule 17.17.10.8 Noise

- (a) The noise generated by any activity shall comply with the following noise limits in Tables A and B, unless specific noise limits are provided for the activity elsewhere in the plan. All noise measurements and assessments shall be conducted in accordance with NZS6801:2008 Acoustics – Measurement of Environmental Sound and NZS6802:2008 Acoustics – Environmental Noise.

TABLE A

The noise level measured at or within the boundary of a site zoned Residential or the notional boundary of a site zoned Rural shall not exceed the following:

ACTIVITY	L _{Aeq} dB		L _{Amax} dB
	MONDAY TO – SUNDAY 7.00AM – 10.00PM (0700-2200)	AT ALL OTHER TIMES	
Beachlands Village Business Centre Zone			10.00PM- 7.00AM (2200-0700)

	50	40	70
--	----	----	----

TABLE B

The noise level as measured at or within the boundary of any adjacent site zoned Beachlands Village Business Centre Zone shall not exceed the following limits:

ACTIVITY	L_{Aeq} dB		L_{Amax} dB
Beachlands Village Business Centre Zone	MONDAY TO – SUNDAY 7.00AM – 10.00PM (0700-2200)	AT ALL OTHER TIMES	10.00PM- 7.00AM (2200- 0700)
	60	60	90

- (b) Household units shall only be permitted in the Beachlands Village Business Zone where an acoustic design certificate is provided by the applicant demonstrating that the accommodation has been designed in such a manner so as to comply with the following internal noise limits:

TABLE C

ACTIVITY	L_{dn} dBA	L_{Amax} dB
Household units in Beachlands Village Business Centre Zone	45	55

- (c) The noise shall be measured with a sound level meter complying at least with the International Standard IEC 651 (1979) Sound Level Meters, Type 1.

- (d) Any construction, maintenance and demolition noise shall comply with Rule 5.18.3.6 in Chapter 5 - General Procedures and Rules.
- (e) The maximum noise levels specified in Tables A and B shall not apply to:
 - (i) Noise from safety signals, warning devices, or emergency pressure relief valves, provided they do not sound for more than a reasonable period;
 - (ii) Crowd noise associated with outdoor events;
 - (iii) Any noise emitted by any aircraft being operated during or immediately before or after flight.
- (f) Notwithstanding the noise standards in Tables A and B, the Council may invoke the powers conferred on it under the relevant sections of the Resource Management Act 1991 to control any noise which has become an objectionable element or nuisance.
- (g) Business activities which propose to operate 24 hour heating, ventilating and air conditioning and similar equipment within 50 meters of any site zoned residential, must demonstrate that the noise emission will comply with the noise performance standards specified in the plan.
- (h) Business activities which require heavy vehicle deliveries to be made between 2200-0700 hours and are sited within 50 metres of any site zoned residential, must demonstrate that the noise emission generated by the vehicles will comply with the noise performance standards specified in Rule 14.11.8.
- (i) The noise limits specified in Table A, B or C may be exceeded by the maximum of 10dBA during the daytime period only for sporting, recreational and cultural activities, provided that such activities do not occur more than 2 times in any 12 month period and for the period of not more than 3 hours on any single occasion (the daytime period is defined as 7.00am to 10.00pm).
- (j) Notwithstanding clause (a) of this Rule, activities undertaken in the Beachlands Village Business Centre Zone shall not exceed 55 L10 dBA at any time within 1 metre of the façade of any building used solely for education purposes on land designated for such purposes. Where buildings on designated school sites are used for residential accommodation then clause (a) of this Rule shall apply.

Explanation/Reason

The main purpose of the noise controls for the Beachlands Village Business Zone is to protect adjoining residential zones from the potential for adverse effects of intrusive noise. The noise controls adopted are the same as those adopted for the Business 2 (Suburban Centres) Zone. As well as providing for noise protection on residential boundaries it is also appropriate that some

acoustic control is provided between sites within the zone. A mixture of activities is likely to establish within the zone and some activities may require an appropriate level of acoustic privacy.

Rule 17.17.10.9 Vibration

Rule 5.18.4 Vibration contained in Chapter 5 – General Procedures and Rules applies.

Rule 17.17.10.10 Hazardous Facilities and Substances

Rules contained in Chapter 10.1 – Hazardous Facilities and Substances apply.

Rule 17.17.10.11 Odour, Dust, Fumes and Smoke

(a) Odour

Activities must not create offensive or objectionable odour able to be detected at or beyond the boundary of the site. In the event of an offensive or objectionable odour occurring to such an extent that it has, or is likely to have an adverse effect on people, places or resources, such action shall be taken as may be necessary by the owner and / or occupier to remedy the situation to the satisfaction of the Council.

(b) Dust, Fumes and Smoke

Activities shall not create a dust, fume or smoke nuisance. A dust, fume or smoke nuisance will be deemed to have occurred if:

- there is visible evidence of suspended solids / particulate matter in the air beyond the site boundary; and / or
- there is visible evidence of deposited particulate matter traceable from a dust source, settling on the ground, building or structure on an adjoining site or waterbody.

Note: This Rule shall not apply to construction activities.

Explanation/Reason

The existing dust, fume, smoke and odour controls for the Business Areas have been adopted for the Beachlands Village Business Centre Zone to ensure that a consistent approach for the management of offensive or objectionable odours and / or dust, fume or smoke nuisances in the business environments of the District is maintained. Flexibility is needed so that various alternatives can be used to avoid or reduce the problem. The control adopted for the business areas recognises both the subjective nature of the task and the need to provide for flexibility to take whatever action is needed to solve the problem.

Rule 17.17.10.12 Lighting

Rule 5.18.2 Artificial Lighting contained in Chapter 5 – General Procedures and Rules applies provided that references in that rule to residential sites shall also apply to sites in the Whitford Rural Zone.

Rule 17.17.10.13 Signs

Rule 5.14.9 Contained in Chapter 5 – General Procedures and Rules applies except that the following signs shall be Permitted Activities in the Beachlands Village Business Centre Zone:

- (i) A sign not exceeding 4m² in area identifying the name of a specific neighbourhood, community or business area provided that no sign shall be flashing, a variable message sign, or reflective.
- (ii) A single free-standing sign for each street frontage to a site, where the primary purpose of the sign is identification, with the total height of the support structure and sign not exceeding 7m and the area of the sign not exceeding 15m² where the sign is single sided or 30m² where the sign is double sided with a maximum horizontal dimension of 3.5m.

Provided that where there is more than one premise on the site, one composite sign of the above mentioned height and width may be erected on each street frontage subject to the total area of the sign being limited to a maximum of 3.0m² for each premises to a total area of 15m² where the sign is single sided or 30m² where the sign is double sided.

In the case of sites with a frontage in excess of 100m to a road the maximum height of the single free-standing sign on that frontage may be extended to ~~9m~~ 8m and the maximum area extended to 20m² for a single sided sign and 40m² for a double sided sign.

Provided that part of the support structure of the sign in the form of a pole or mast may extend up to 1m above the maximum sign height for the sole purpose of supporting lighting fittings for the sign.

- (iii) For any activity with a gross floor area exceeding 3000m² signs on each façade of the building with an area not exceeding 65m² with a maximum length of 25m and / or a maximum height of 7m.
- (iv) All signs, except neon signs may be externally, internally or halo illuminated.

Note: Rule 5.14.9 and Rule 17.17.10.13 do not apply to Service Stations and All Associated Signage that are Controlled Activities

Explanation/Reason

The provision of signage within the Beachlands Village Business Zone is a necessary feature of this zone given that retail and commercial buildings will be the dominant feature in this area. As with all business areas there is an expectation that there will be a variety of signage displayed on

buildings, within car parking areas and on free standing signs. Consequently signage forms part of the amenity values attributed to the business area and the potential impact of signs is reduced. However, if signage is poorly sited and designed it can cause visual clutter, confusion and can be a traffic hazard. These development and performance standards therefore provide an appropriate threshold for signs to ensure that the potential for adverse effects are avoided or mitigated.

Rule 17.17.10.14 Water Supply

All activities shall comply with the following:

- (a) The following water conservation devices shall be used in all new buildings:
 - (i) dual flush 6/3 litre toilets;
 - (ii) showerhead flow restrictors;
 - (iii) aerator taps.
- (b) Provision shall be made for sufficient water supply and access to water supplies for fire fighting purposes consistent with NZ Fire Service Fire Fighting Water Supplies Code of Practice SNZ PAS 4509: 2008 (or subsequent amendments)

Rule 17.17.10.15 Erosion / Sediment Control

- (a) All provisions in Chapter 9 – Land Modification, Development and Subdivision shall apply.
- (b) All earthworks shall be undertaken in general accordance with the Erosion / Sediment Control Measures in Appendix 5.
- (c) All sediment controls shall be provided in accordance with the Beachlands Integrated Catchment Management Plan (ICMP) or approved Network Discharge Consent.

Rule 17.17.10.16 Retail Activities

- (a) No more than a combined total 6,700m² Gross Floor Area (excluding loading and servicing areas) of Building Improvement Centres, Convenience Shops, Garden Centres, Retail Sales, Retail Activities, Shops, Stalls and Supermarkets shall be constructed within the Beachlands Village Business Centre Zone prior to 1 January 2017.
- (b) No more than a combined total 8,500m² Gross Floor Area (excluding loading and servicing areas) of Building Improvement Centres, Convenience Shops, Garden Centres, Retail Sales, Retail Activities, Shops, Stalls and Supermarkets shall be constructed within the Beachlands Village Business Centre Zone.

Note: Cafes, Restaurants, bars and taverns are excluded from the Gross Floor Area restrictions applying in the above rule.

Explanation / Reason

The Beachlands Village Business Centre is intended to be a mixed use centre that enables a range of retail activities in order to service the needs of the existing and growing community in conjunction with a mix of commercial and other activities such as childcare centres, hotels and motels, cinemas and community facilities. To ensure that the business centre will provide for an appropriate mix and range of retail, commercial and other activities and can sustainably service the existing and growing community over the long term the extent of retail provision provided within the business centre needs to be managed. This will also ensure that the potential impact of small store displacement from other business zones will be minimised. A total of 8,500m² can realistically be sustained over the long term within the business centre based on the expected growth in population in the catchment to 2026. Over the short term to 2016 a total of 6,700m² can realistically be sustained. Retail development in excess of these levels has the potential to generate adverse effects which need to be appropriately assessed.

Rule 17.17.10.17 Staging

- (a) The first stage of any development shall include:-
 - (i) The development of the Landscape Buffer Area/Landscaped Setback in accordance with Rule 17.17.10.3.
 - (ii) Development of all of the Surface Carpark area as shown on the Beachlands Village Business Centre Concept Plan.
 - (iii) Construction and vesting with Council of a Collector Road between Beachlands Road and the boundary of Lot 2 DP 325925, no later than the time at which any part of Stage 1 of the business development is open to the public.
- (b) Any development including a supermarket shall be subject to a separate premise or premises being developed at the same time (if not already established beforehand) on the Beachlands Road side of the supermarket.

Explanation / Reason

Development is anticipated in accordance with the Concept Plan Appendix 1. An important feature of that plan is an anticipated Main Street function for Karaka Road. It is therefore important that large buildings such as a supermarket, are appropriately “sleeved” by suitably designed buildings to front Karaka Road, and other street frontages in accordance with the active street frontage rule. Similarly, it is important that the supermarket is adequately sleeved by a suitably designed building between the supermarket and Beachlands Road.

It is acknowledged, however, that it may not be viable to build the sleeved component at first instance and therefore a landscaping requirement is imposed as an interim use for the land on the Beachlands Road side of the supermarket, pending building development in accordance with the Concept Plan (see Rules 17.17.12.21 and 17.17.12.22). On the Karaka Road side of the

supermarket, the layout of development must enable the future development of both sides of Karaka Road as a main street (see Rule 17.17.11.2(b)(vi)).

Landscaping, including in parking areas, is particularly important to provide for a village business centre that maintains the qualities of the existing Beachlands settlement.

Construction of a north-south collector road running from Beachlands Road to the boundary of Lot 2 DP 325925 will ensure that there is adequate access to the business development from the Beachlands Village: New Avenues area to the south.

17.17.11 RULES – MATTERS FOR CONTROL: CONTROLLED ACTIVITIES

Rule 17.17.11.1 Council reserves control over the following matters for controlled activity resource consent applications for the construction, erection or relocation of any building (excluding service stations) and/or external alterations or additions to any building (excluding service stations) and may impose conditions in respect of these matters:

- (i) Design and external appearance
- (ii) Site layout
- (iii) Pedestrian amenity and access
- (iv) Vehicle access
- (v) Water supply
- (vi) Lighting

Rule 17.17.11.2 When assessing an application for a controlled activity resource consent for the construction, erection or relocation of any building (excluding service stations) and/or external alterations or additions to any building (excluding service stations) the Council will have regard to the following assessment criteria:

(a) Design and External Appearance

- (i) Whether the building design and external appearance will maintain the visual amenity values of the business centre and the surrounding Beachlands settlement, in particular whether:
 - The design contains variety that provides richly articulated building facades which both integrate with neighbouring buildings while providing differences which promote the variety required;
 - The design creates a sense of human scale and in particular whether the facades through their articulation break down the bulk and mass of the building;

- The design provides for massing which is additive in that it can be perceived that one building has been added to another. Given the nature of the business centre this may take on a façade type exercise, but where possible this should be integrated into the design with the use of other techniques such as modeling;
- The design presents a varied and irregular skyline within practical limitations. The effect desired is a low richly varied skyline to the streetscape;
- The design ensures that the building frontage contains a number of small steps (no greater than 1 metre) backwards / forwards along its length to create depth and solidity to the façade;
- The design (particularly if presenting a long façade) develops a rhythm through the major elements of the façade such as bays or individual shop units. Even in a vibrant chaotic façade it is through the provision of rhythm that a sense of harmony to the façade as a whole is created;
- The design is generously and richly articulated and detailed to provide a high quality modern architectural solution. Richness in articulation is most important at eye level and can be provided through architectural detail or the use of materials. Natural materials provide for richness because of the innate depth to their finish and form;
- The design limits its materials palette to natural materials (such as timber and stone), steel (particularly profiled sheets), concrete (in a variety of finishes) and glazing (curtain walling would be acceptable). It is intended that the materials palette will present a modern interpretation of the rural vernacular that surrounds the area; and
- The design presents a colour palette in which warm tones reflecting the earthy landscape and recessive colours such as greys predominate. The roof areas are to be finished in dark recessive colours.

(b) Site Layout

- (i) Whether the layout of buildings, external spaces, parking areas and loading and servicing areas achieve general compliance with the Beachlands Village Business Centre Concept Plan contained in Appendix 1.
- (ii) Whether any minor deviations from the Beachlands Village Business Centre Concept Plan contained in Appendix 1 will maintain the overall intent of the Beachlands Village Business Centre Concept Plan.

- (iii) Whether the site layout fosters a pedestrian focus and interaction with the street, and avoids internal mall-type development.
- (iv) Whether the layout of the building creates the opportunity for the development of open space plazas, seating areas, public amenities or similar facilities contributing to the amenity values of the business centre.
- (v) Whether the layout of the building has considered how the building will relate to public open space and whether the building will positively address public open space.
- (vi) Whether the layout proposed enables the future development of both sides of Karaka Road as shown on the Beachlands Village Business Centre Concept Plan as a main street.

(c) Pedestrian Amenity and Access

- (i) Whether pedestrian routes to buildings are direct, convenient, legible and attractive.
- (ii) Whether pedestrian amenity has been given a high priority in the design approach for the building so that people are encouraged to walk within the business centre.
- (iii) Whether the design approach for the building promotes an integrated pedestrian network that provides a network of through pedestrian routes that seamlessly join the existing framework of pedestrian routes.
- (iv) Whether the design approach for the building promotes an integrated pedestrian network that balances the needs of all users of the business area; pedestrians, cyclists, cars, service vehicles and public transport.
- (v) Whether the design approach for the building incorporates a high standard of pedestrian provision including canopies, generous pavement widths, street furniture such as seating and attention to detail such as dropped kerbs which the elderly will not find difficult to negotiate.
- (vi) Whether landscaping proposals create a close link between the pedestrian network and the landscape network creating lush vibrantly planted pedestrian paths.
- (vii) Whether the practice of integration of pedestrian movement and landscaping gives the opportunity to appropriately consider CPTED principles to ensure a safe environment is created.
- (viii) Whether the provision of artificial lighting has been carefully considered to ensure safety for pedestrians after dark.

- (ix) Whether pedestrians are provided with legible and direct access to the building with level access provided at main entrances to the building.

(d) Vehicle access

- (i) All relevant criteria in Chapter 8 Transportation shall apply.
- (ii) Whether vehicular access to the site provides for safe and convenient access that maintains the safe and efficient operation of the adjoining road network.
- (iii) Whether vehicle access has minimal disruption on pedestrian access and safety.

(e) Water supply

- (i) Whether water efficiency and conservation measures have been used to reduce the reliance on ground water resources.

(f) Lighting

- (i) Whether the design of light fittings and light poles (including in terms of placement, aiming, height, and screening) minimises light spill, glare, loss of night sky viewing, and adverse effects on visual amenity from the surrounding rural environment, having regard to current relevant standards and codes of practice.

Rule 17.17.11.3 Council reserves control over the following matters for controlled activity resource consent applications for the construction or reconstruction and / or formation or reformation of roads, at grade car parking areas and open space areas and may impose conditions in respect of these matters:

- (i) Visual amenity values.
- (ii) Streetscape character.
- (iii) The extent, type and nature of landscaping.
- (iv) The maintenance of plantings.
- (v) Lighting.
- (vi) Road Design.

Rule 17.17.11.4 When assessing an application for a controlled activity resource consent for the construction or reconstruction and / or formation or reformation of roads, at grade car parking areas and open space areas the Council will have regard to the following assessment criteria:

- (i) Whether the landscape proposal can achieve general consistency with the Beachlands Village Business Centre Landscape Design Framework contained in Appendix 3.
- (ii) Whether the specimen trees included in the landscape proposal are capable of achieving a minimum height of 8 metres or more at maturity and a planting grade of 160 litres or larger.
- (iii) Whether the landscape proposal is designed to create visual interest and contribute to the visual amenity of the business area and surrounding area.
- (iv) Whether the landscape proposal relates appropriately to and is designed to further enhance the existing streetscape and landscape character of the business area.
- (v) Whether the landscape proposal will soften the visual impact of structures and minimise conflicts of scale.
- (vi) Whether the landscape proposal provides for an appropriate level of visual screening of parking and loading areas and outdoor storage areas.
- (vii) Whether the landscape proposal adequately provides for the maintenance of plantings at a reasonable maintenance cost.
- (viii) Whether the location and design of the at grade car parking areas provides for convenience and a safe and efficient circulation pattern.
- (ix) Whether planting within the at grade car parking areas makes a contribution to creating a sense of place within the business centre consistent with the Landscape Design Framework.
- (x) Whether low level grasses and specimen trees have been used to provide a strong presence within the at grade car parking areas and to reduce the impact of the hard surfaced area consistent with the Landscape Design Framework.
- (xi) Whether opportunities have been taken to introduce high quality surface materials and street furniture within the at grade car parking areas.
- (xii) Whether the at grade car parking areas provide for attractive gateway spaces to the business centre.
- (xiii) Whether landscaping features may affect visibility at intersections or pedestrian and traffic safety.
- (xiv) Whether the design of light fittings and light poles (including in terms of placement, aiming, height, and screening) minimises light spill, glare, loss of night sky viewing, and adverse effects on visual

amenity from the surrounding rural environment, having regard to current relevant standards and codes of practice.

- (xv) Whether roads are designed so that carriageways align at intersections with other existing or proposed roads.
- (xvi) Whether roads are designed having regard to the Landscape Design Framework in Appendix 3.
- (xvii) Whether the Landscape Buffer Area can be accessed from Karaka Road for maintenance purposes (physical vehicle access is not required to the Landscape Buffer Area from the road but provision should be available within the surrounding local road network for the parking of maintenance vehicles).

Rule 17.17.11.5 Council reserves control over the following matters for controlled activity resource consents applications for Service Stations and may impose conditions in respect of these matters:

- (i) Design and external appearance.
- (ii) Landscaping.
- (iii) Access, parking and manoeuvring.
- (iv) Signage.
- (v) Hazardous substances.
- (vi) Lighting.

Rule 17.17.11.6 When assessing an application for a controlled activity resource consent for Service Stations the Council will have regard to the following assessment criteria:

- (i) Whether the design and external appearance of the service station is sensitive to the amenity of the adjoining and adjacent business and residential activities.
- (ii) Whether the site is adequately landscaped to soften and screen the service station from the adjoining and adjacent business and residential activities consistent with the Landscape Design Framework.
- (iii) Whether appropriate screening of the service station from adjoining and adjacent business and residential activities has been achieved through the use of methods such as mounding, fencing, walls and other features.
- (iv) Whether the vehicle access and egress from the site ensures that adequate sight distances are maintained.

- (v) Whether the vehicle access and egress from the site has been suitably designed to allow for easy access to the site and to prevent on street congestion.
- (vi) Whether the site provides for adequate on-site parking and provides for adequate manoeuvring space for heavy vehicles and service vehicles.
- (vii) Whether the signage to be provided on the site has had regard to the assessment criteria contained in Rule 5.14.10.2.
- (viii) Whether the storage and use of hazardous substances on the site has had regard to the assessment criteria contained in Rule 10.1.10.2.
- (ix) Whether the design of light fittings and light poles (including in terms of placement, aiming, height, and screening) minimises light spill, glare, loss of night sky viewing, and adverse effects on visual amenity from the surrounding rural environment, having regard to current relevant standards and codes of practice.

17.17.12 RULES – MATTERS FOR DISCRETION: RESTRICTED DISCRETIONARY ACTIVITIES

Rule 17.17.12.1 Council reserves control over the following matters for restricted discretionary activity resource consent applications for any permitted, controlled or restricted discretionary activity in Rule 17.17.9.2 which does not comply with the development and performance standards in 17.17.10.1 Height and may impose conditions in respect of these matters:

- (i) Sunlight and daylight, particularly protection of access to sunlight and daylight for adjoining properties.
- (ii) Visual amenity values, particularly compatibility of the height of buildings and other structures in the surrounding area.
- (iii) Disruption to view shafts, particularly the northern view shaft from the Whitford-Maraetai Road.
- (iv) Design and external appearance, particularly the scale and form of the building.
- (v) Character of surrounding area, particularly the effects on the character of the Beachlands Village Business Centre.

Rule 17.17.12.2 When assessing an application for a restricted discretionary activity for any permitted, controlled or restricted discretionary activity in Rule 17.12.9.2 which does not comply with the development and performance standards in Rule 17.12.10.1 Height the Council will have regard to the following assessment criteria:

- (i) Whether the increase in height will have an adverse effect on the access of sunlight and daylight to adjoining sites.
- (ii) Whether the proposed height of the building and other structures will be compatible with the height and visual character of the surrounding area, particularly of any adjoining residential areas.
- (iii) Whether the height of the building will disrupt views north to the sea and coastal edge from the Whitford-Maraetai Road.
- (iv) Whether the location, design and external appearance of the building is compatible with that of buildings in the surrounding area, particularly whether the form and scale of the building is in keeping with the character of the surrounding area.
- (v) Whether the proposed height of the buildings and other structures will be compatible with the prevailing character of the Beachlands Village Business Centre.

Rule 17.17.12.3 Council reserves control over the following matters for restricted discretionary activity resource consent applications for any permitted, controlled or restricted discretionary activity in Rule 17.17.9.2 which does not comply with the development and performance standards in 17.17.10.2 - Yards – Sites Within Business Area A and may impose conditions in respect of these matters:

- (i) Amenity values, particularly streetscape and landscape elements.
- (ii) Landscape planting, particularly the extent and quality of landscape planting, in association with ground contouring provided along the Whitford-Maraetai Road.
- (iii) Density, particularly coverage of buildings on sites adjoining the Whitford-Maraetai Road.

Rule 17.17.12.4 When assessing an application for a restricted discretionary activity for any permitted, controlled or restricted discretionary activity in Rule 17.17.9.2 which does not comply with the development and performance standards in Rule 17.17.10.2 - Yards – Sites Within Business Area A the Council will have regard to the following assessment criteria:

- (i) Whether the proposal will be compatible with the prevailing amenity values of the area, in particular the amenity of sites adjoining the Whitford-Maraetai Road, and whether landscape and / or architectural elements will be provided to soften any building development.
- (ii) Whether the proposed activity provides for protection of the northern view shaft from the Whitford-Maraetai Road.

Rule 17.17.12.5 Council reserves control over the following matters for restricted discretionary activity resource consent applications for any permitted, controlled or restricted discretionary activity in Rule 17.17.9.2 which

does not comply with the development and performance standards in 17.17.10.4 – Canopies and Verandas and may impose conditions in respect of these matters:

- (i) Design and appearance.
- (ii) Height above ground level.

Rule 17.17.12.6 When assessing an application for a restricted discretionary activity for any permitted, controlled or restricted discretionary activity in Rule 17.17.9.2 which does not comply with the development and performance standards in Rule 17.17.10.4 – Canopies and Verandas the Council will have regard to the following assessment criteria:

- (i) Whether the design of the canopy has taken into account the adjoining canopies to ensure that an integrated streetscape is achieved.
- (ii) Whether continuous shelter for pedestrians can be provided.
- (iii) Whether the appearance of the canopy adds to the overall composition of the façade of the building.
- (iv) Whether the canopy can provide for adequate protection from the elements for pedestrians.
- (v) Whether the width of canopy is sufficient in relation to the height above ground level of the canopy.

Rule 17.17.12.7 Council reserves control over the following matters for restricted discretionary activity resource consent applications for any permitted, controlled or restricted discretionary activity in Rule 17.17.9.2 which does not comply with the development and performance standards in 17.17.10.5 – Active Street Frontage 1 and Rule 17.12.10.6 Active Street Frontage 2 and may impose conditions in respect of these matters:

- (i) Design and appearance.
- (ii) Landscape design.
- (iii) Length of inactive street frontage.
- (iv) CPTED measures.

Rule 17.17.12.8 When assessing an application for a restricted discretionary activity for any permitted, controlled or restricted discretionary activity in Rule 17.17.9.2 which does not comply with the development and performance standards in Rule 17.17.10.5 Active Street Frontage 1 and Rule 17.12.10.6 Active Street Frontage 2 the Council will have regard to the following assessment criteria:

- (i) Whether other development in the immediate vicinity provides activity and vibrancy in this area of the street, public open space or open space.

- (ii) Whether other development in the immediate vicinity provides passive surveillance over this area of the street, public open space or open space.
- (iii) Whether the architectural design provides interest and richness through the quality of composition, articulation / detail and materials.
- (iv) Whether landscaping can provide an appropriate treatment which adds interest and richness to the overall design.
- (v) Whether the length of the inactive street frontage has been minimised as far as possible.
- (vi) Whether other uses that can provide for layouts that would introduce active street frontages can be shown to be inappropriate or impractical.

Rule 17.17.12.9 Council reserves control over the following matters for restricted discretionary activity resource consent applications for any permitted, controlled or restricted discretionary activity in Rule 17.17.9.2 which does not comply with the development and performance standards in 17.17.10.7 Screening of Activities and Storage and may impose conditions in respect of these matters:

- (i) Visual amenity.

Rule 17.17.12.10 When assessing an application for a restricted discretionary activity for any permitted, controlled or restricted discretionary activity in Rule 17.17.9.2 which does not comply with the development and performance standards in Rule 17.17.10.7 Screening of Activities and Storage the Council will have regard to the following assessment criteria:

- (i) Whether the outdoor storage of goods, materials, refuse or refuse containers impacts on the level of visual amenity anticipated in the Beachlands Village Business Centre.

Rule 17.17.12.11 Council reserves control over the following matters for restricted discretionary activity resource consent applications for any permitted, controlled or restricted discretionary activity in Rule 17.17.9.2 which does not comply with the development and performance standards in 17.17.10.13 Signs and may impose conditions in respect of these matters:

- (i) Traffic safety, including vehicular and pedestrian safety.
- (ii) Visual amenity values, including scale, bulk, location, form, construction, lighting, landscaping and cumulative effects.

Rule 17.17.12.12 When assessing an application for a restricted discretionary activity for any permitted, controlled or restricted discretionary activity in Rule 17.17.9.2 which does not comply with the development and performance standards in Rule 17.17.10.13 Signs the Council will have regard to the assessment criteria contained in Rule 5.14.10.2.

Rule 17.17.12.13 Council reserves control over the following matters for restricted discretionary activity resource consent applications for Household Units and may impose conditions in respect of these matters:

- (i) Safety of the occupants of the household unit.
- (ii) Internal noise environment within the household unit.
- (iii) Site layout, design and appearance.

Rule 17.17.12.14 When assessing an application for a restricted discretionary activity for Household Units the Council will have regard to the following assessment criteria:

- (i) Whether there is a level of risk to the safety of the occupants of a household unit due to the layout of the surrounding buildings and the nature of the surrounding activities.
- (ii) Whether the household unit is designed and constructed in a manner which provides a satisfactorily internal noise environment with regard to noise levels prevailing in the surrounding business area.
- (iii) Whether compliance has been achieved with Rule 17.17.10.8 (b) Noise.
- (iv) Whether the Design Code for Intensive Housing contained in Appendix 1 to Chapter 13 – Residential Areas: Appendices has been complied with as an integrated document.
- (v) Whether consideration has been given to the Auckland City Council and the North Shore City Council guidance document ‘Good Solutions Guide for Apartments’ (ISBN 970-0-473-11999-7) where applicable.

Rule 17.17.12.15 Council reserves control over the following matters for restricted discretionary activity resource consent applications for any permitted, controlled or restricted discretionary activity in Rule 17.17.9.2 which does not comply with the development and performance standards in Rule 17.17.10.14 Water Supply and may impose conditions in respect of these matters:

- (i) Use of water efficiency and conservation measures.
- (ii) The availability of water for firefighting purposes.

Rule 17.17.12.16 When assessing an application for a restricted discretionary activity for any permitted, controlled or restricted discretionary activity in Rule 17.17.9.2 which does not comply with the development and performance standards in Rule 17.17.10.14 Water Supply the Council will have regard to the following assessment criteria:

- (i) Whether water efficiency and conservation measures are required to sustain the ground water resource.

- (ii) Whether sufficient water supply and access to water supplies has been provided for firefighting purposes.

Rule 17.17.12.17 Council reserves control over the following matters for restricted discretionary activity resource consent applications for Building Improvement Centres, Cafes, Restaurants, Takeaway Food Premises and Tearooms, Convenience Shops, Garden Centres, Retail Sales, Retail Activities, Shops and Stalls and Taverns in Stage 2 and may impose conditions in respect of these matters:

- (i) Design and external appearance.
- (ii) Site layout.
- (iii) Pedestrian amenity and access.
- (iv) Roading and vehicle access.
- (v) Water supply.
- (vi) Delay to the creation of a main street character along Karaka Road.
- (vii) Visual amenity and character.

Rule 17.17.12.18 When assessing an application for a restricted discretionary activity for Building Improvement Centres, Cafes, Restaurants, Takeaway Food Premises and Tearooms, Convenience Shops, Garden Centres, Retail Sales, Retail Activities, Shops and Stalls and Taverns in Stage 2 the Council will have regard to the following assessment criteria:

- (i) The assessment criteria in Rule 17.17.11.2.
- (ii) Whether compliance can be achieved with the General Development and Performance Standards contained in Rule 17.17.10.
- (iv) The relevant assessment criteria in Rule 17.17.12 – Rules – Matters for Discretion: Restricted Discretionary Activities or Rule 17.17.13 – Assessment Criteria: Discretionary Activities where compliance cannot be achieved with any of the General Development and Performance Standards contained in Rule 17.17.10.
- (v) Whether development within Stage 2 may result in a unreasonable delay to the completion of development along Karaka Road that could compromise the achievement of a main street character along this road.
- (vi) Whether any potential for delay to the completion of development along Karaka Road will create adverse effects on visual amenity and character.

Rule 17.17.12.19 Council reserves control over the following matters for restricted discretionary activity resource consent applications for Convenience Shops and Retail Sales, Retail Activities, Shops and Stalls in Business Area A and may impose conditions in respect of these matters:

- (i) Design and external appearance.

- (ii) Site layout.
- (iii) Pedestrian amenity and access.
- (iv) Rooding and vehicle access.
- (v) Water supply.
- (vi) Delay to the creation of a main street character along Karaka Road.
- (vii) Visual amenity and character.

Rule 17.17.12.20 When assessing an application for a restricted discretionary activity for Convenience Shops and Retail Sales, Retail Activities, Shops and Stalls in Business Area A the Council will have regard to the following assessment criteria:

- (i) The assessment criteria in Rule 17.17.11.2.
- (ii) Whether compliance can be achieved with the General Development and Performance Standards contained in Rule 17.17.10.
- (iii) The relevant assessment criteria in Rule 17.17.12 – Rules – Matters for Discretion: Restricted Discretionary Activities or Rule 17.17.13 – Assessment Criteria: Discretionary Activities where compliance cannot be achieved with any of the General Development and Performance Standards contained in Rule 17.17.10.
- (iv) Whether development within Business Area A may result in a unreasonable delay to the completion of development along Karaka Road that could compromise the achievement of a main street character along this road.
- (v) Whether any potential for delay to the completion of development along Karaka Road will create adverse effects on visual amenity and character.

Rule 17.17.12.21 Council reserves control over the following matters for restricted discretionary activity resource consent applications for any permitted, controlled or restricted discretionary activity in Rule 17.17.9.2 which does not comply with the development and performance standards in Rule 17.17.10.17(b) Staging and may impose conditions in respect of these matters:

- (i) Ensuring that any development including a supermarket does not inhibit the future establishment of a building between the supermarket and Beachlands Road as envisaged by the Beachlands Village Business Centre Concept Plan (Appendix 1).
- (ii) The adequacy of mitigation of adverse visual effects until such time as a building is constructed between the supermarket and Beachlands Road.

- (iii) The adequacy of provision made for pedestrian amenity and safety.

Rule 17.17.12.22 When assessing an application for a restricted discretionary activity for any permitted, controlled or restricted discretionary activity in Rule 17.12.9.2 which does not comply with the development and performance standards in Rule 17.17.10.17(b) Staging the Council will have regard to the following assessment criteria:

- (i) Whether any development including a supermarket inhibits the future establishment of a building between the supermarket and Beachlands Road as envisaged by the Beachlands Village Business Centre Concept Plan (Appendix 1).
- (ii) The adequacy of building design and any interim screening or landscaping between the supermarket and Beachlands Road to provide adequate mitigation of adverse visual effects of the supermarket as viewed from Beachlands Road, until such time as a building is established between the supermarket and Beachlands Road as envisaged by the Beachlands Village Business Centre Concept Plan (Appendix 1). In particular, this mitigation is to provide adequate screening of the supermarket wall facing Beachlands Road so that a planted rather than built appearance dominates the view from that direction. The landscaping is also to complement landscaping proposed along Beachlands Road (see Indicative Street Typology 6 in Appendix 3: Landscape Design Framework).
- (iii) Whether the site layout fosters a pedestrian focus and interaction with the street.
- (iv) Whether the practice of integration of pedestrian movement and landscaping gives the opportunity to appropriately consider CPTED principles to ensure a safe environment is created.
- (v) Whether the provision of artificial lighting has been carefully considered to ensure safety for pedestrians after dark.

17.17.13 ASSESSMENT CRITERIA: DISCRETIONARY ACTIVITIES

For all discretionary activity resource consent applications in the Beachlands Village Business Centre Zone the Council will have regard to the following assessment criteria:

(a) Effects on People and Communities

- (i) Whether the proposal will have adverse effects on the ability of people to provide for their social and economic wellbeing.
- (ii) Whether the proposal will have adverse effects on the safe and efficient operation of the surrounding transportation network.

- (iii) Whether measures have been taken to ensure the provision of safe and efficient access, parking and loading facilities that can avoid, remedy or mitigate any potential for adverse effects on the surrounding transportation network.
- (iv) Whether the proposal has made adequate provision for infrastructure including reticulated infrastructure for wastewater disposal, stormwater collection, treatment and disposal facilities, on site and / or off site infrastructure for the supply of potable water and telecommunications and power supply facilities.

(b) Amenity Values

- (i) Whether the proposal has the potential to have adverse effects on the amenity values of adjoining residential and / or public open space zones.
- (ii) Whether the proposal will generate unreasonable levels of noise, which may be noise levels that exceed the limits stated in Rule 17.17.10.8.
- (iii) Whether the proposal will have adverse effects on the amenity values within the Beachlands Village Business Centre. In particular whether the proposal will detract from a main street character, and one that is based on developments having an active frontage to streets or open space plazas.

(c) Landscape and Visual Effects

- (i) Whether the proposal has the potential to have adverse landscape and visual effects on the amenity values of the adjoining residential, rural and / or public open space zones.
- (ii) Whether the proposal will have adverse landscape and visual effects on the amenity values within the Beachlands Village Business Centre. In particular whether the proposal will detract from the character that has been established within the Beachlands Village Business Centre.
- (iii) Whether the proposal will have adverse visual effects on the identified northern view shaft from Whitford-Maraetai Road.
- (iv) Whether the proposal is supported by a landscape and visual impact assessment which has considered the assessment criteria for activities within the Beachlands Village Centre Zone and which has demonstrated how the general intent of the Beachlands Village Business Centre Landscape Design Framework can be maintained.

(d) Site Layout

- (i) Whether the grid layout of the road network that exists within the Beachlands settlement is supported and adopted by the proposal.
- (ii) Whether the proposal provides an integrated movement network (including parking requirements) which balances the needs of

pedestrians, cyclists, private vehicles, public transport and service vehicles creating a safe and effective movement network.

- (iii) Whether the layout generally supports the road network as envisaged within the Beachlands Village Business Centre Concept Plan including supporting positive streetscapes by generally providing a continuous back of pavement building line and the provision of active frontages.
- (iv) Whether the proposal prioritises, supports and maintains Karaka Road as the main shopping street.
- (v) Whether vehicular access points support Karaka Road as the main shopping street and maintain a positive pedestrian movement network.
- (vi) Whether the open space provision is maintained allowing the Beachlands Village Business Centre Landscape Design Framework to be implemented.
- (vii) Whether the proposal can be shown to support the 'New Zealand Urban Design Protocol' and safety principles embodied by international movement 'Crime Prevention Through Environmental Design' (CPTED).
- (viii) Whether the locations of activities support: one another, an effective movement network, the grid street network, continuous back of pavement building lines, Karaka Road as the main shopping street, pedestrian amenity, landmark features, New Zealand Urban Design Protocol, CPTED, and the open space provisions including the Beachlands Village Business Centre Landscape Design Framework.
- (ix) Whether the proposal is supported by an urban design report which has considered the assessment criteria for activities within the Beachlands Village Centre Zone and which has demonstrated how the general intent of the Beachlands Village Business Centre Concept Plan can be maintained.

(e) Effects on Ecosystems

- (i) Whether the proposal will have adverse effects on water quality, and whether measures have been included in accordance with the Network Discharge Consent for the Beachlands Village: New Avenues area to ensure that any potential for degradation of water quality is avoided, remedied or mitigated.
- (ii) Whether measures have been taken to ensure that any potential adverse effects on the ecosystem can be avoided, remedied or mitigated.

(f) Discharge of Contaminants to the Environment

- (i) Whether the proposal will generate dust, smoke, fumes or other discharges to air which could potentially distract from the amenity values of the area.

- (ii) Whether the proposal will generate objectionable odours which can be contained within the site.

(g) Risk of Hazards

- (i) Whether the proposal will expose people to high levels of risk to their health and safety.

(h) Distributional impacts on other Business Zones in Beachlands.

When assessing an application for retail floorspace not meeting the standards in Rule 17.17.10.16 Retail Activities:-

- (i) Whether the retail activity will impact on the form, function and vitality of the existing retail activities located within the business zones within Beachlands.
- (ii) Whether an assessment of retail demand has been provided and whether this assessment demonstrates a demand for the additional retail floor space proposed and that the Beachlands Village Business Centre Zone is an appropriate location for these building types and anticipated uses.

(i) Lighting

- (i) Whether the design of light fittings and light poles (including in terms of placement, aiming, height, and screening) minimises light spill, glare, loss of night sky viewing, and adverse effects on visual amenity from the surrounding rural environment, having regard to current relevant standards and codes of practice.

RULE 17.17.14 SUBDIVISION

17.17.14.1 All subdivision shall be a Controlled Activity where the subdivision:

- (a) is consistent with the Beachlands Village Business Centre Concept Plan contained in Appendix 1; and
- (b) is either integrated with a resource consent for buildings or follows the completion of buildings; and
- (c) ensures the location of the boundaries as defined in Chapter 18 comply with the development and performance standards for the zone with the exception of Rule 17.17.10.2 for sites within Business Area A shown on the Beachlands Village Business Centre Concept Plan contained in Appendix 1 where subdivision is either incorporated with a resource consent for buildings or follows the completion of buildings.

Otherwise subdivision shall be a Discretionary Activity.

17.17.14.2 Rules in Chapter 9 – Land Modification, Development and Subdivision apply except that there shall be no minimum site size.

- 17.17.14.3 Rules in Chapter 8 – Transportation apply except where there is a conflict with any Rule or Appendix in Rule 17,17, in which case Rule 17.17 shall apply.
- 17.17.14.4 Council reserves control over the following matters for controlled activity resource consent applications for subdivision and may impose conditions in respect of these matters:
- (i) Subdivision design
 - (ii) Road Design
 - (iii) Site layout and access
 - (iv) Pedestrian amenity and access
 - (v) Vehicle parking and access
- 17.17.14.5 When assessing an application for a controlled activity resource consent for subdivision the Council will have regard to the assessment criteria in Rules 17.17.11.2 (b), (c) and (d) and 17.17.11.4:
- 17.17.14.6 When assessing an application for a discretionary activity resource consent for subdivision the Council will have regard to the assessment criteria in Rules 17.17.11.2 (b), (c) and (d), 17.17.11.4 and 17.17.13.

3. Beachlands Village Business Centre Appendix 1: Concept Plan

(Note: delete the red circles around “Constellation Avenue”, “Collector Road” and “BVBC Roads” annotations shown in the Concept Plan when updating the District Plan).

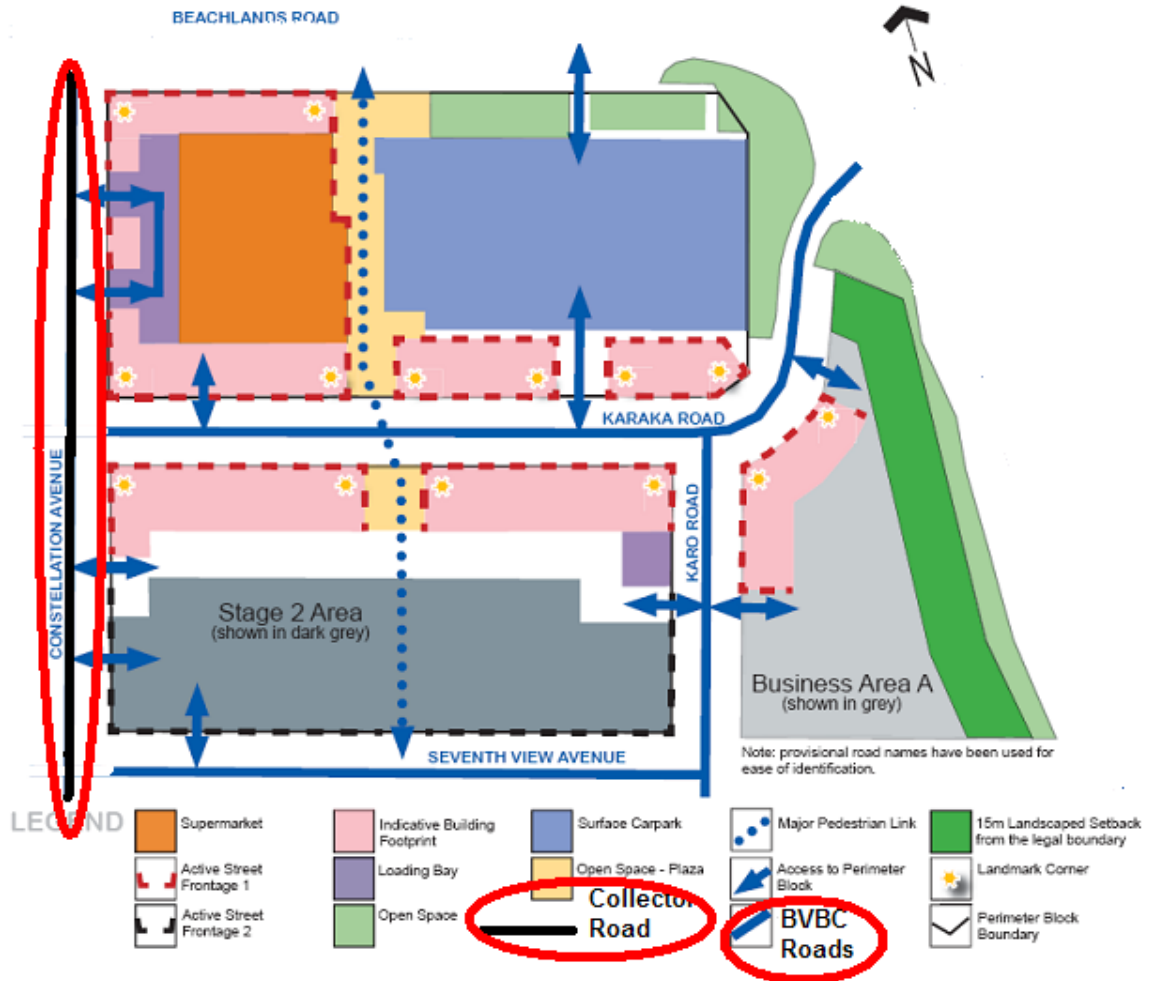

4. Beachlands Village Business Centre Appendix 2: Height Areas Plan

Beachlands Village Business Centre Appendix 2: HEIGHT AREAS

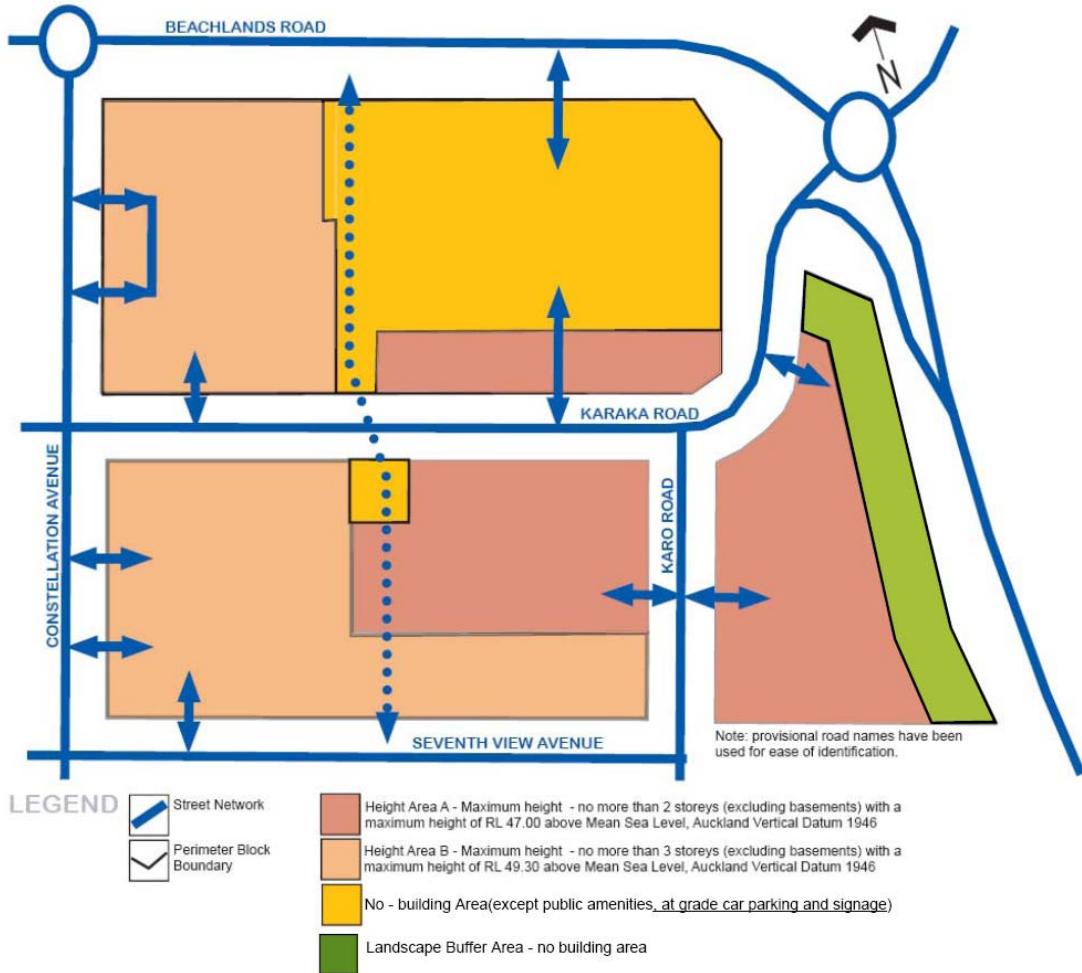

5. Beachlands Village Business Centre Appendix 3: Landscape Design Framework

Beachlands Village Business Centre: Appendix 3: Landscape Design Framework 1 - Karaka Road

Indicative Street Typology

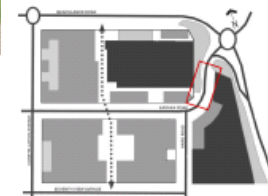
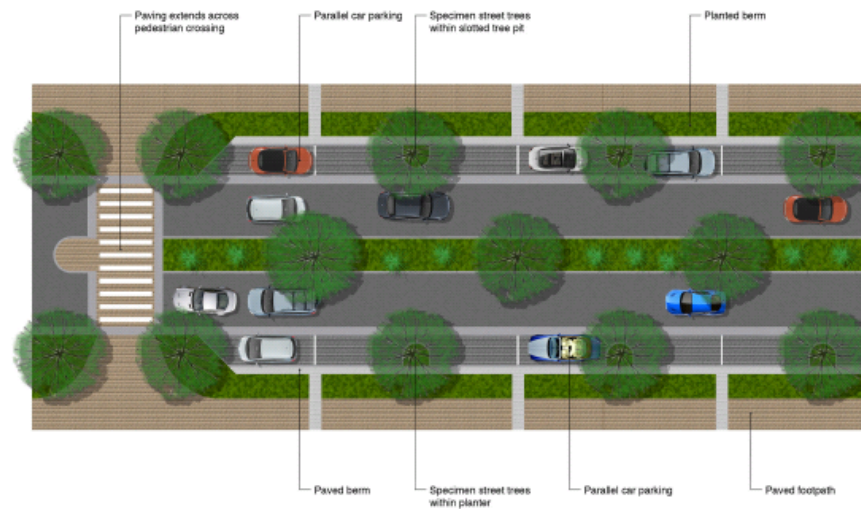
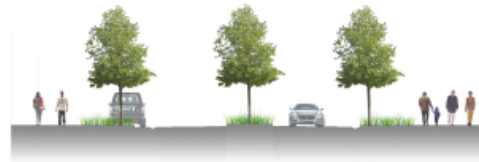

Beachlands Village Business Centre: Appendix 3: Landscape Design Framework 2 - Karaka Road

Indicative Street Typology

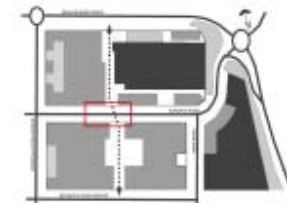
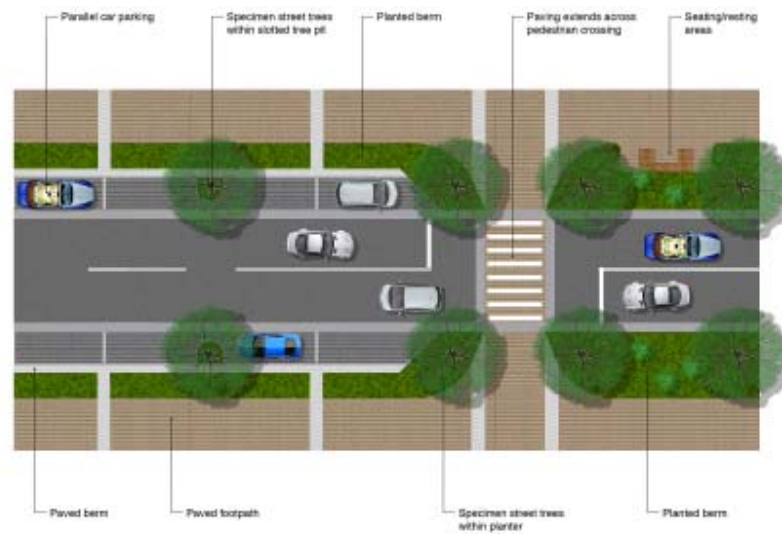

Beachlands Village Business Centre: Appendix 3: Landscape Design Framework 3 - Karaka Road

Indicative Street Typology

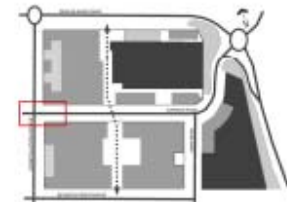

Beachlands Village Business Centre: Appendix 3: Landscape Design Framework 4 - Constellation Avenue

Indicative Street Typology

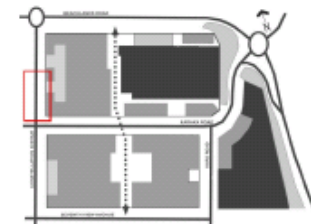
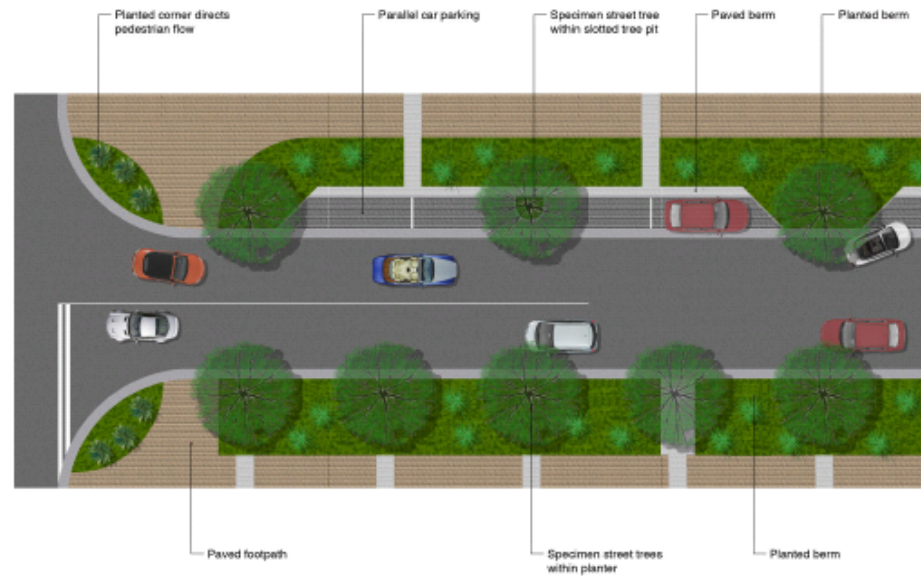

Beachlands Village Business Centre: Appendix 3: Landscape Design Framework

5 - Karo Road

Indicative Street Typology

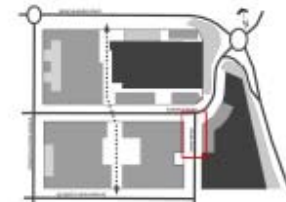

Beachlands Village Business Centre: Appendix 3: Landscape Design Framework 6 - Beachlands Road

Indicative Street Typology

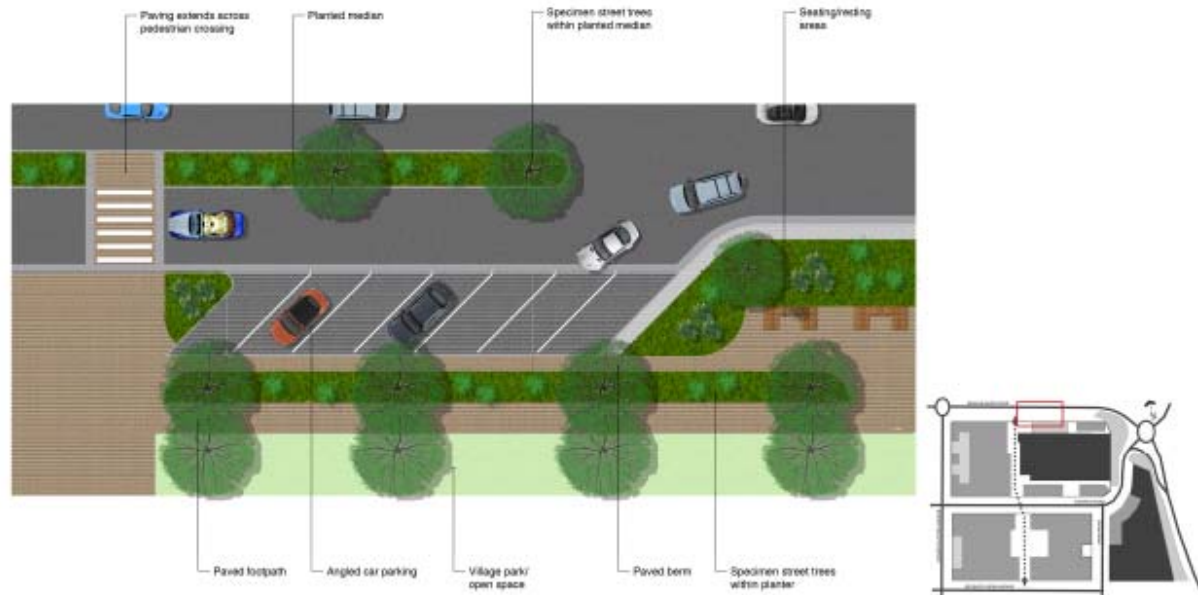

Beachlands Village Business Centre: Appendix 3: Landscape Design Framework 7 - Typical Carpark Layout

Indicative Street Typology

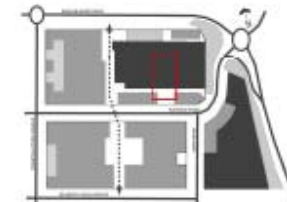

Beachlands Village Business Centre: Appendix 3: Landscape Design Framework 8 - Open Space - Karaka Road

Indicative Street Typology

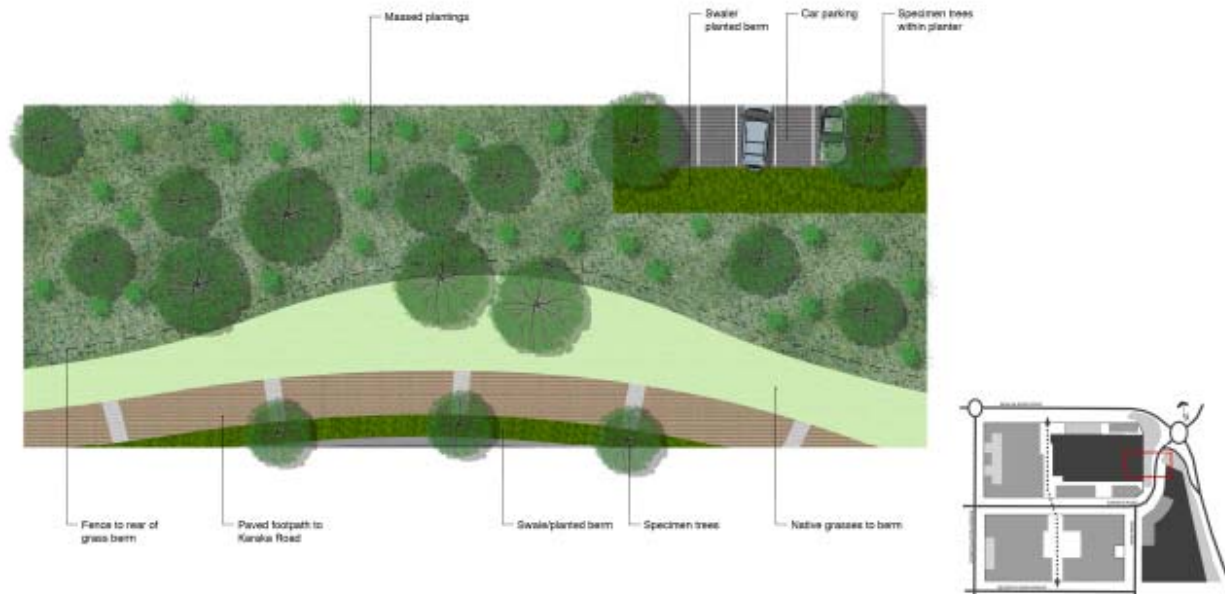

Beachlands Village Business Centre: Appendix 3: Landscape Design Framework

9 – Open Space – Whitford – Maraetai Road

Indicative Street Typology



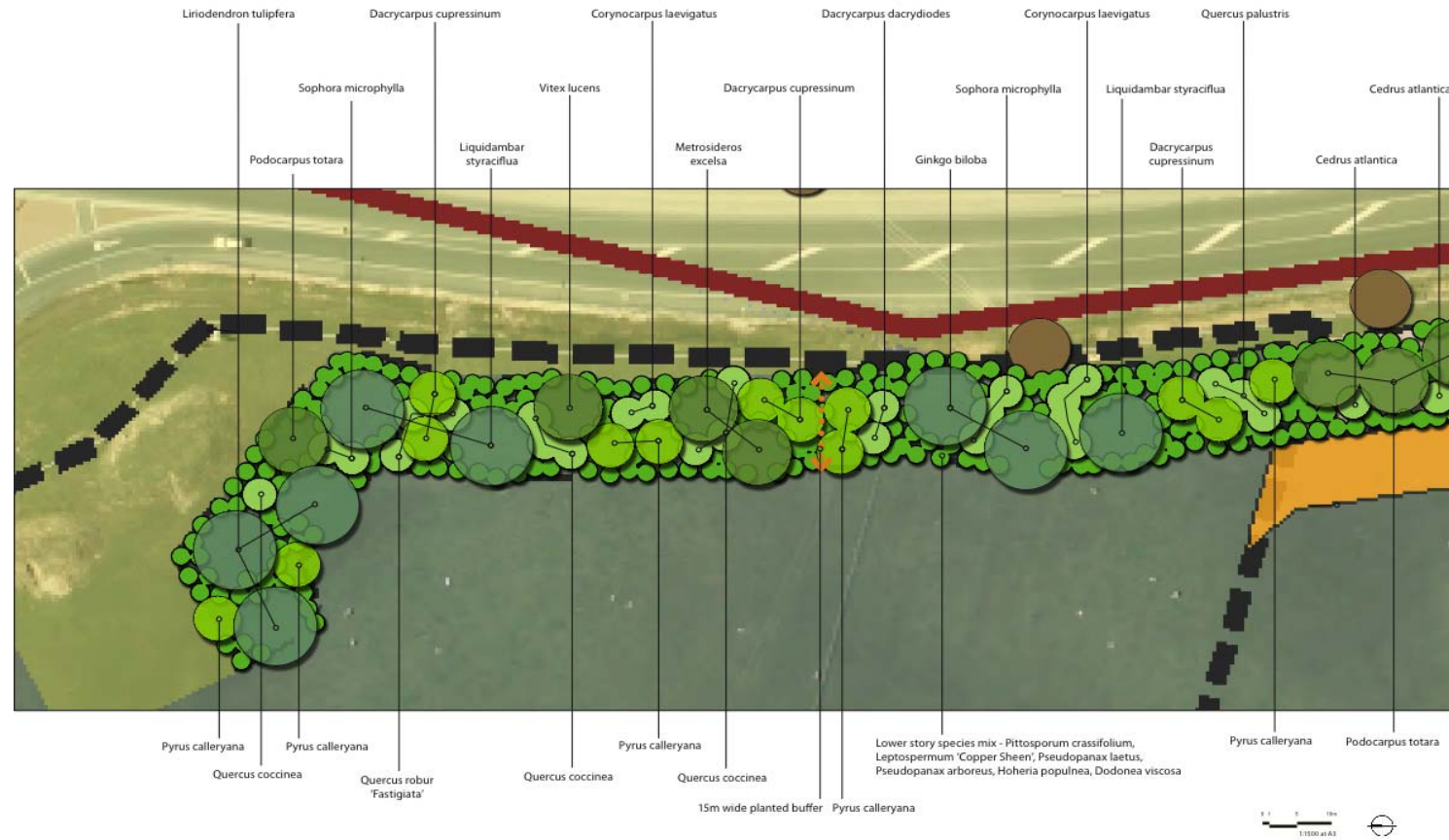

Beachlands Landscape Buffer
 Beachlands | Auckland

EXAMPLE PLANTING PLAN - PC30A AREA

SK-003
 20 June 2012 | Schematic Design

Beachlands Landscape Buffer

Planting Schedule

Date: 19.06.2012

This schedule relates to the planting areas indicated on the planting plans SK001 to 003

Code	Botanical Name	Common Name	Min PB size	Min Height When Planted (mm)	Spacing (mm)	Percentage/ Number
Medium to Large Trees						100%/130
DAC cup	Dacrycarpus cupressinum	Rimu	PB95	2500	As shown	10%/13
DAC dac	Dacrycarpus dacrydioides	Kahikatea	PB95	2500	As shown	10%/13
GIN bil	Ginkgo biloba	Ginkgo	PB95	2500	As shown	10%/13
LIR tul	Liriodendron tulipifera	Tulip tree	PB95	2500	As shown	10%/13
LIQ sty	Liquidambar styraciflua	American sweet gum	PB95	2500	As shown	20%/26
MET exc	Metrosideros excelsa	Pohutukawa	PB95	2500	As shown	20%/26
POD tot	Podocarpus totara	Totara	PB95	2500	As shown	10%/13
VIT luc	Vitex lucens	Puriri	PB95	2500	As shown	10%/13
Small to Medium Trees						100%/220
CED atl	Cedrus atlantica	Atlas cedar	PB50	2000	As shown	10%/22
COR lae	Corynocarpus laevigatus	Karaka	PB50	2000	As shown	20%/44
PYR cal	Pyrus calleryana	Callery pear	PB50	2000	As shown	20%/44
SOP mic	Sophora microphylla	Kowhai	PB50	2000	As shown	20%/44
QUE coc	Quercus coccinea	Scarlet oak	PB50	2000	As shown	10%/22
QUE pal	Quercus palustris	Pin oak	PB50	2000	As shown	10%/22
QUE rob	Quercus robur 'Fastigiata'	Fastigate oak	PB50	2000	As shown	10%/22
Understorey Planting						100%/500
DOD vis	Dodonea viscosa	Akeake	PB28	1500	As shown	20%/100
HOH pol	Hoheria populnea	Lacebark	PB28	1500	As shown	20%/100
LEP cop	Leptospermum 'Copper Sheen'	Manuka hybrid	PB28	1500	As shown	15%/75
PIT cra	Pittosporum crassifolium	Karo	PB28	1500	As shown	15%/75
PSE arb	Pseudopanax arboreus	Five finger	PB28	1500	As shown	15%/75
PSE lae	Pseudopanax laetus		PB28	1500	As shown	15%/75

Contractor to ensure all plants are of a healthy and consistent stock which meet the above requirements. If alternatives are required to meet any of these conditions then the Contractor should propose accordingly to the Landscape Architect.

Beachlands Village Business Centre: Appendix 3: Landscape Design Framework

10 - Open Space - Plaza

Indicative Street Typology

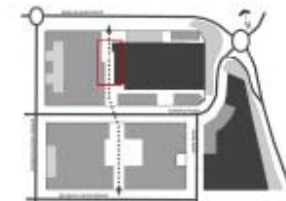
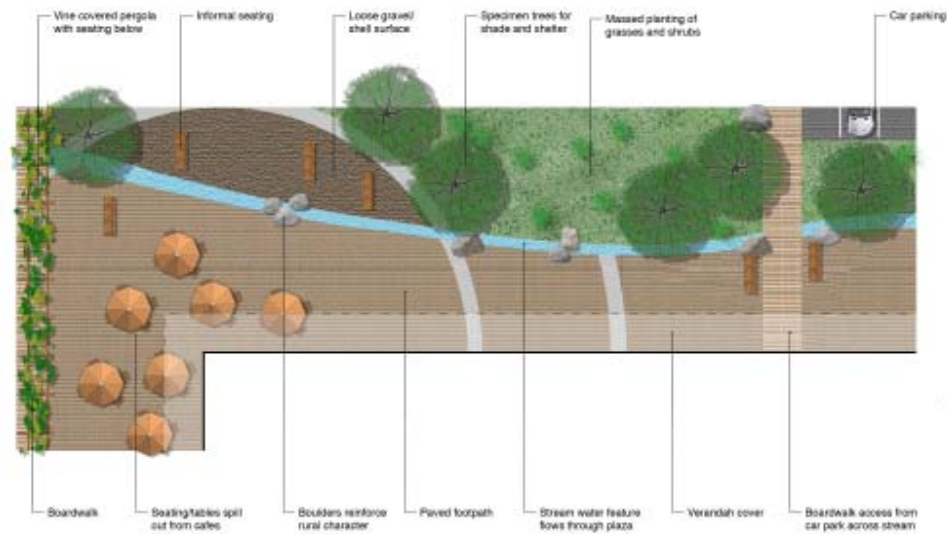

Beachlands Village Business Centre: Appendix 3: Landscape Design Framework 11 - Open Space - Karaka Road / Whitford-Maraetai Road

Indicative Street Typology

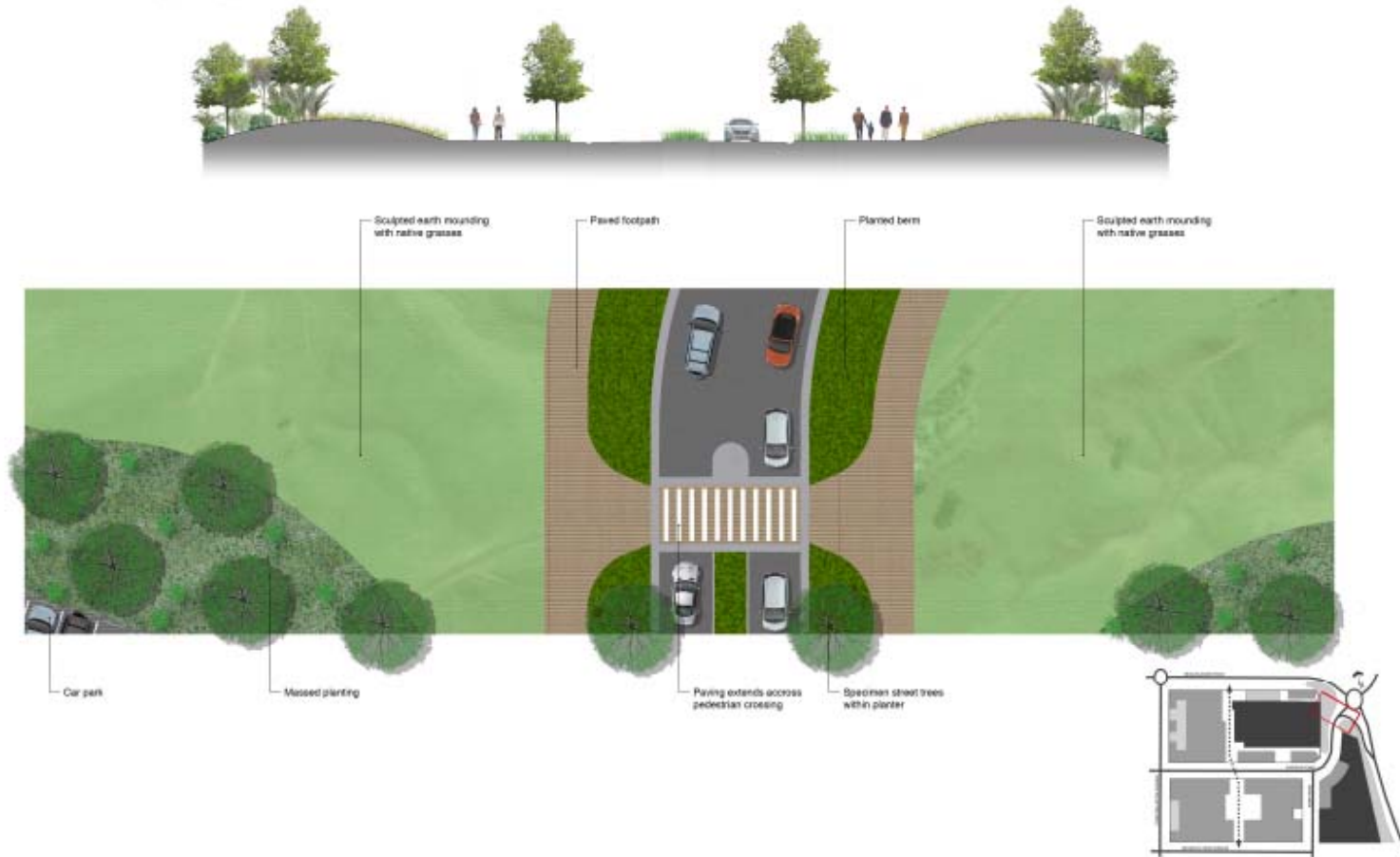

Beachlands Village Business Centre: Appendix 3: Landscape Design Framework

12 – Seventh View Avenue

Indicative Street Typology

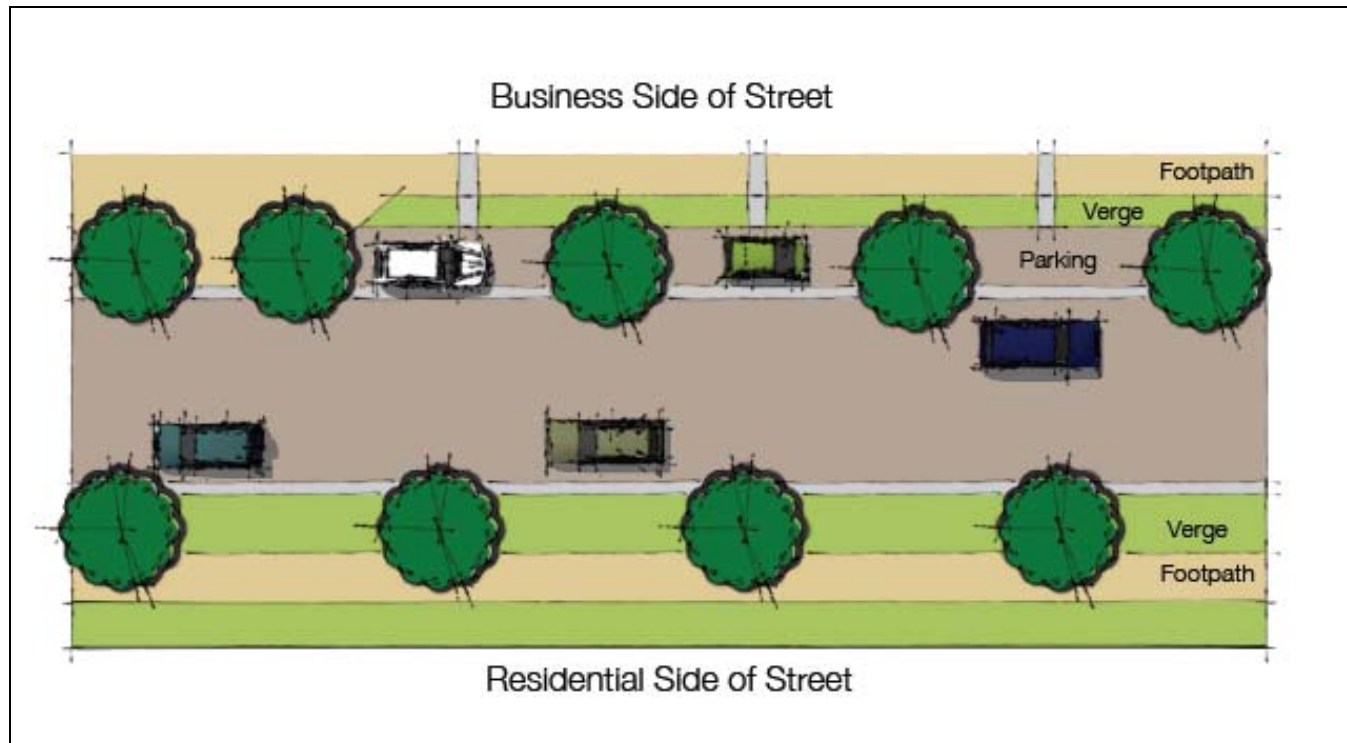

6. Beachlands Village Business Centre Appendix 4: Staging Plan

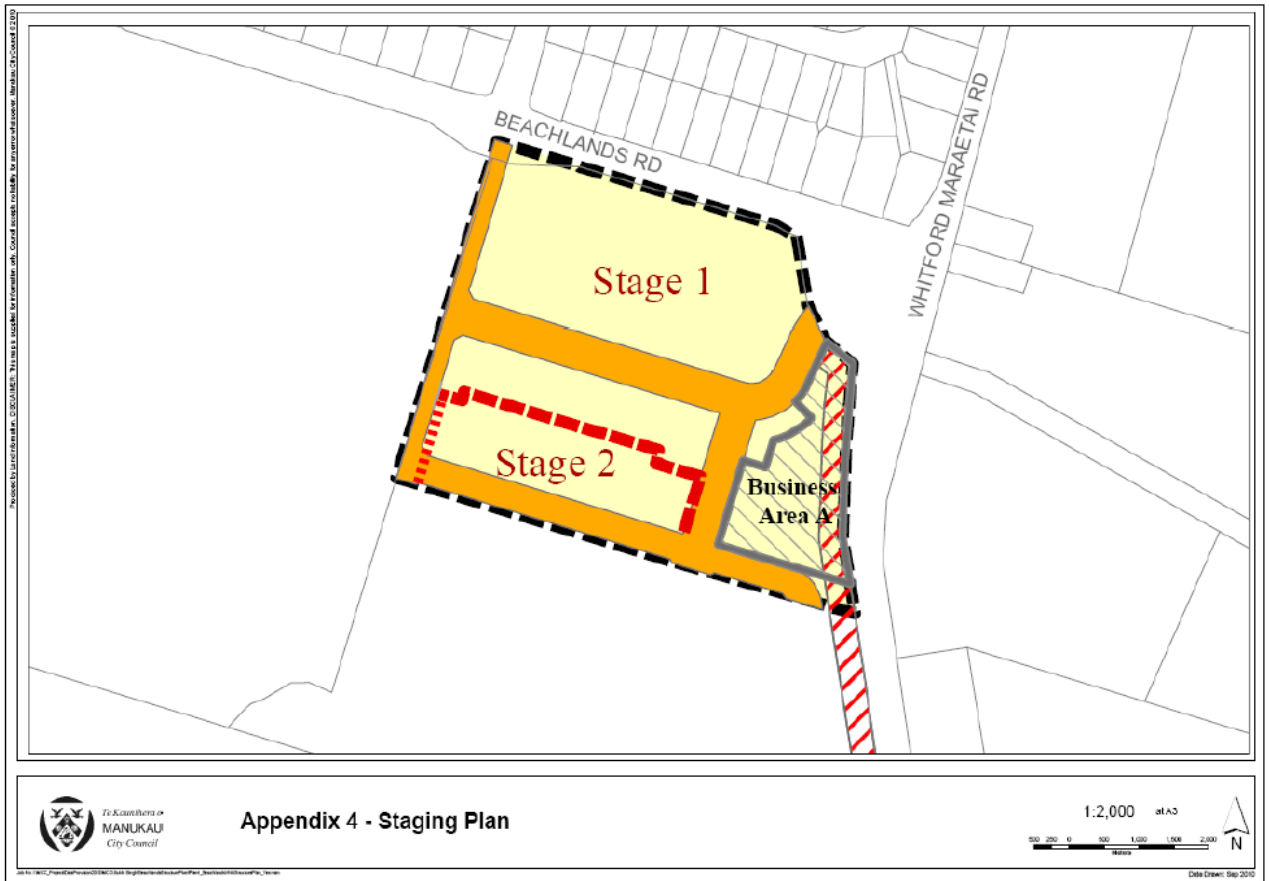

7. Appendix 5 – Erosion and Sediment Control Measures

EROSION AND SEDIMENT CONTROL MEASURES

For Earthworks the following erosion / sediment control measures are to be employed.

EROSION AND SEDIMENT CONTROL MEASURES

1. Mitigate sediment runoff by employing erosion / sediment control measures as follows:
 - Expose only as much ground as needed at any one time
 - Provide run off diversion channels or contour drains to divert clean water away from the site onto stable ground (grassed or sealed)
 - Install a stabilised entrance way
 - Where a building is constructed, ensure that stormwater from the roof is appropriately connected to stormwater systems as soon as the roof is constructed.
 - Regrass / revegetate / stabilise all exposed areas that are not to be worked for more than a 7 day period.

2. Use one or more of the following erosion or sediment control measures for the capturing of silt (see diagrams below):
 - Silt fences
 - Vegetations buffer strips
 - Earth bunds
 - Sediment ponds
 - Pit dewatering (pumping water from the site)

3. Ensure that any sediment control measure is cleaned out before it is 50% full of sediment, and make sure that this material is deposited in a manner that ensures that it cannot runoff into any water bodies or coastal waters.

4. Ensure that maintenance of all erosion and sediment control measures is undertaken as required.

5. Ensure stockpiles of earth are wholly on the construction site and are placed behind a sediment control measure.

6. All silt control measures to be put into place prior to the commencement of the earthworks and to be retained until the site is permanently protected against erosion. (Note: while it is desirable that most controls will be put into place prior to works commencing, there will be some measures that will need to be installed and maintained during the activity).

7. Replace topsoil and regrass / revegetate the exposed ground, or cover up with a mulch, as soon as possible. If working during the winter months (May to September) then mulching will be necessary to ensure a satisfactory vegetative cover is established.

DIAGRAMS OF EROSION AND SEDIMENT CONTROL MEASURES

EROSION CONTROL MEASURES

RUN OFF DIVERSION CHANNELS

- Used to protect work areas from up-slope run off
- Water from channel can be discharged to areas of vegetation
- Can be used to divert water to other sediment retention systems
- Have shallow grades on channel to prevent scouring (1%-2%)
- May need to be stabilised against erosion by regressing

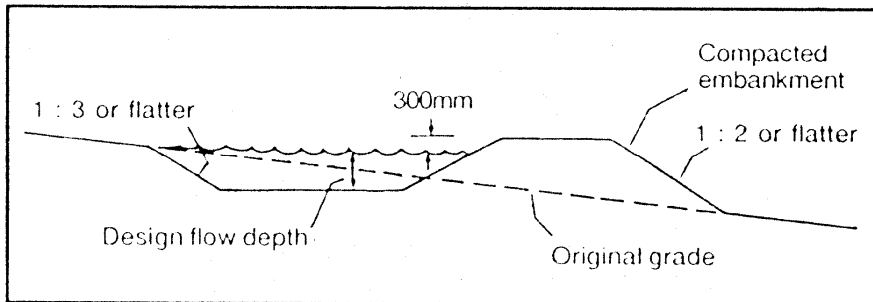

CONTOUR DRAINS

- Use across earthworks to break up slope
- Use more than one drain on steeply sloping sites
- Decrease spacing of drains as slope increases
- Water can be discharged to vegetation or into sediment control structures

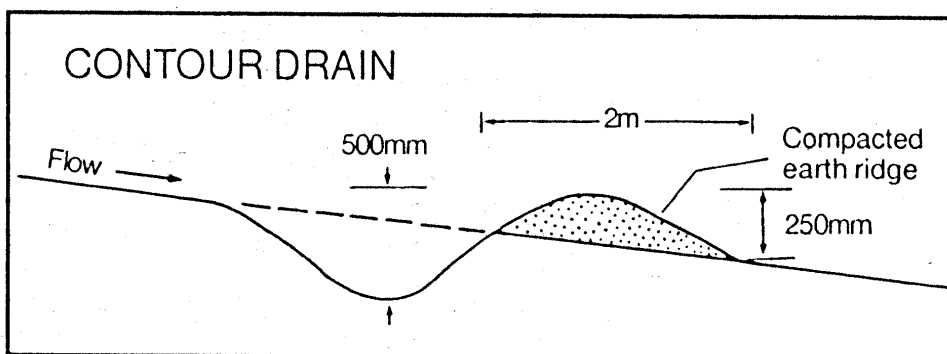

SEDIMENT CONTROL MEASURES

EARTH BUNDS

- Construct across slope to control and detain run-off
- Use near edge of site to prevent sediment from leaving area
- Can use topsoil from site to create bund

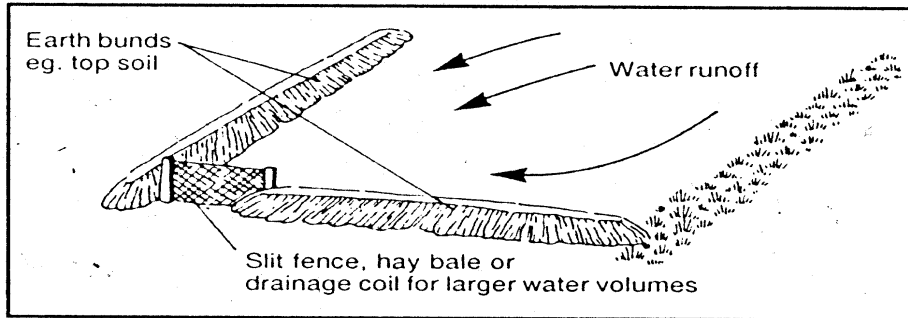

SILT FENCES

- For small disturbed areas or low slope angles
- Use more than one on steeply sloping sites
- Decreased spacing between fences with increasing site slope
- Filter fabric is stretched between posts at max spacing of 1 metre

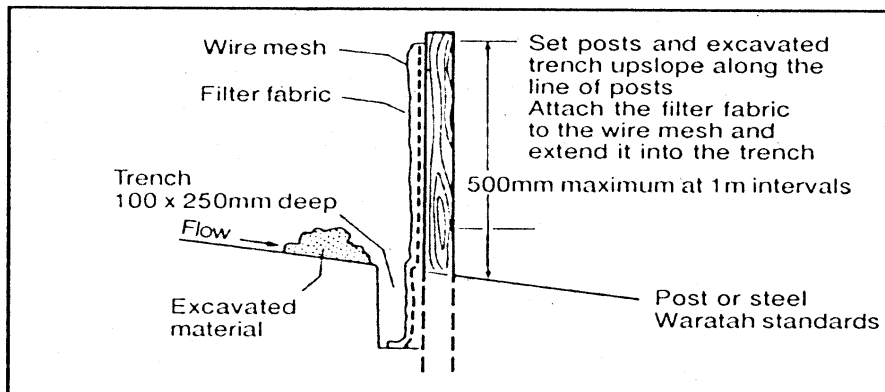

HAY BALES

- For small sites and short term control
- Should be dug into ground, tied together and anchored by staking
- Regular inspection and maintenance is essential

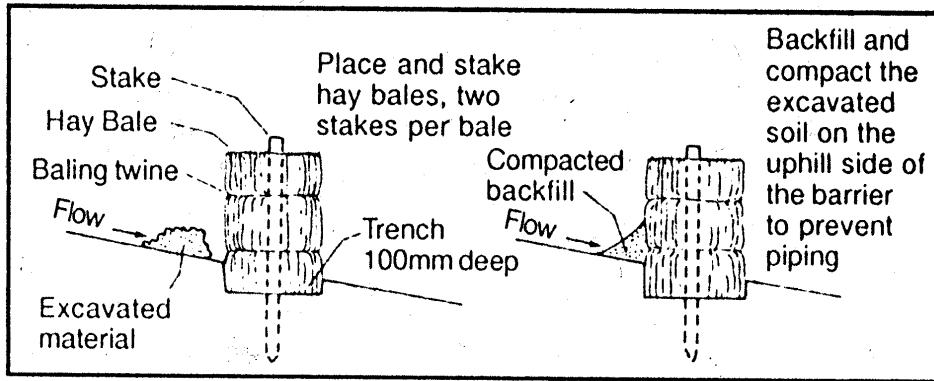

VEGETATION BUFFER STRIPS

- Should always be provided along watercourses
- To filter sediment from overland flow where run off rates are low and not concentrated
- Use more than one buffer strip on steep slopes
- Decrease buffer strip spacing with increasing slope
- To keep machinery away from watercourses

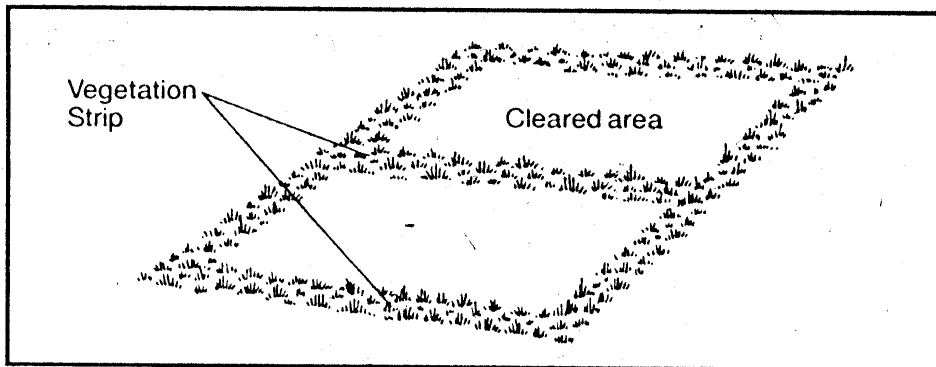

SEDIMENT PONDS

- Do not construct in streams
- Size as 1-2% of site area (ie. $1.2\text{m}^3 / 100\text{m}^2$)
- Clean out sediment regularly
- Must have dewatering / drainage facility

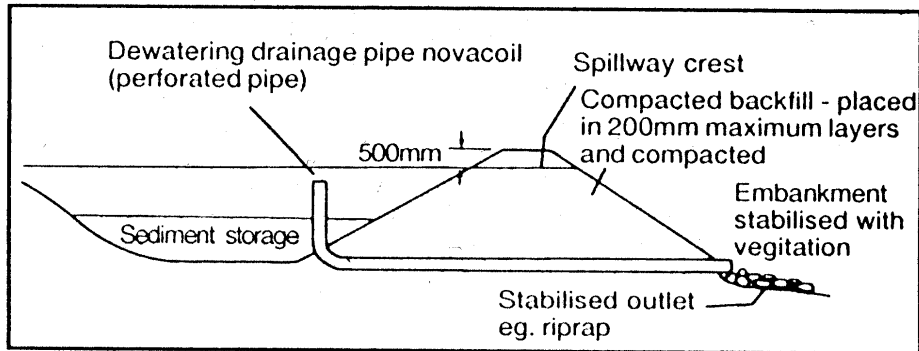

PUMPING WATER FROM THE SITE

If it is necessary to remove water from trenches or other areas of the site, then this should be done in a manner to prevent sediment in the water from entering any drain or watercourse. Water should not be taken from the bottom of any trench and sediment should be properly filtered out from the dirty water by an appropriate means (e.g. vegetative buffer strips). Once the sediment has settled within the trenches water can then be discharged to a cesspit or grassed area, or a watercourse if no other disposal point is available.

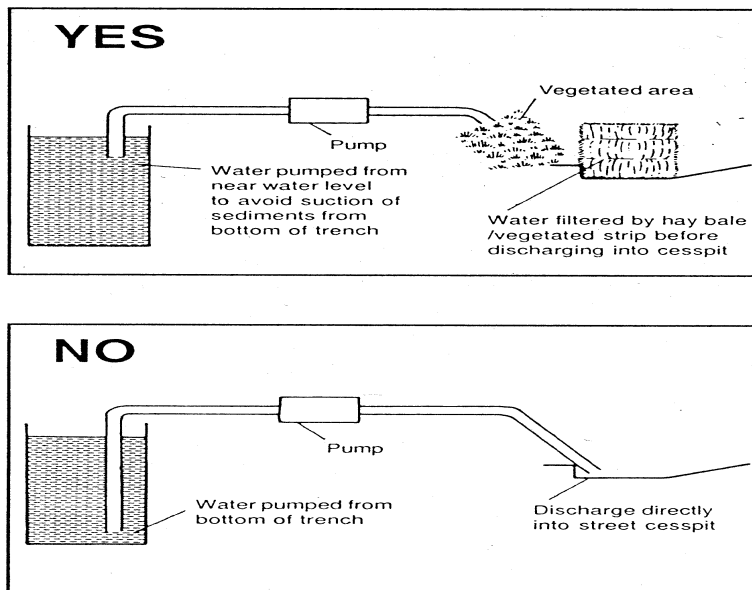

KEEPING THE ROAD CLEAN

It is important that soil from the site is not spread onto the road by vehicle tyres. To prevent this from occurring a stabilised entranceway must be built. The simplest method is to spread metal aggregate on all exit ways from the site where soil will have a chance to gall off before the vehicle enters the road. Other methods for large sites are cattle grids or a wheel wash. The site manager or site owner is responsible for cleaning up any spilt soil or other materials that get onto the road from the site.

Remember also to protect the footpath, berm and kerb from damage by crossing vehicles.

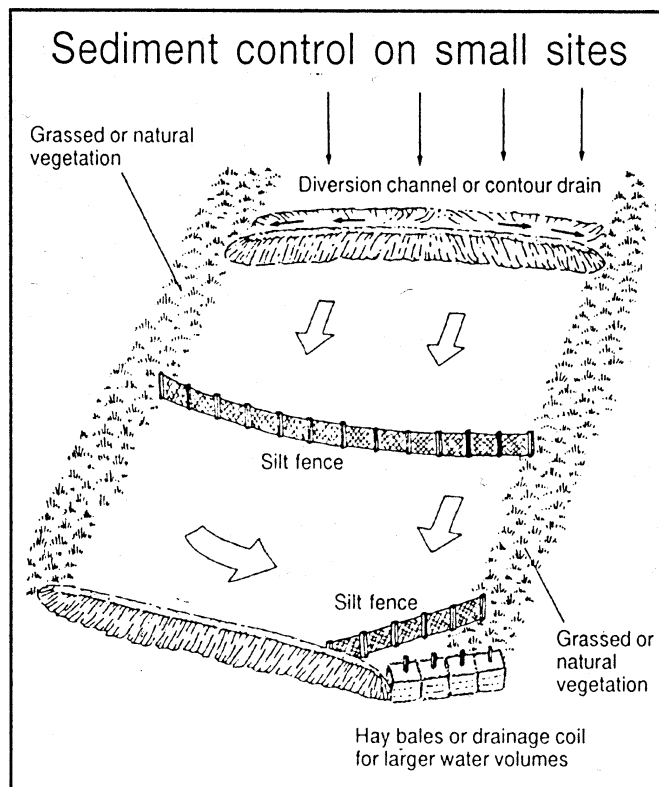
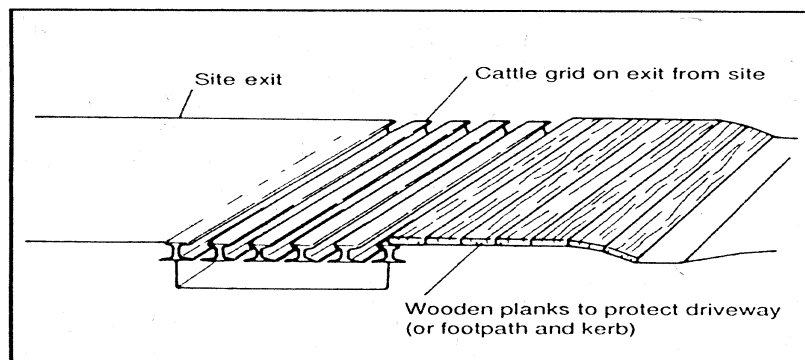
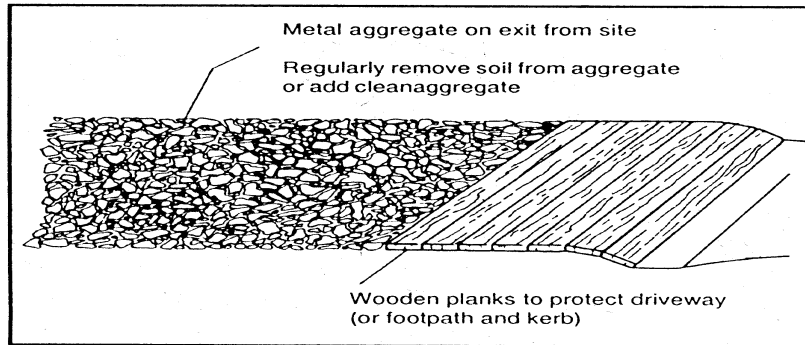

EXPLANATION

This Appendix covers smaller scale earthworks that are Permitted Activities in relation to the district plan. Apart from building platform formation, such 'small site' earthworks are generally for the purpose of driveways, landscaping, paving, or tracking for rural tracks. Small site activities are of concern if no erosion or sediment controls are in place because any sediment generated eventually discharges onto nearby properties, to waterways, or to drains and stormwater systems.

Depending on the location of these works, they can have a direct influence on the receiving environment, an effect that is compounded by the cumulative impact of many operations. In most cases the volume of sediment discharges may be minor, however, it is the cumulative effects that have the potential to be significant to particular environmental qualities. For example, after the Auckland Regional Council has consented earthworks of a 100 lot subdivision, accommodate house platforms, driveways, paths etc. The impact of one property owner re earthworking their site without proper controls is minor however, the cumulative impacts from 100 property owners re-earthworking without controls can be significant in terms of sediment generated. It is this cumulative effect that is of most concern.

8. Amendments to Chapter 5 – General Procedures and Rules

Note: Amendments to text are shown as insertions underlined and deletions ~~struck through~~.

(a) **AMEND** Rule 5.14.9.3 as follows:

5.14.9.3 Signs in the Residential, Rural, Future Development, and the Special Zones (except the Beachlands Village Business Centre, Quarry, Boat Harbour and Health Care Activities Zones) ...

(b) **AMEND** Rule 5.14.9.5 as follows:

5.14.9.5 Signs in the Business, Beachlands Village Business Centre, Flat Bush Town Centre, Flat Bush Neighbourhood Centre, Quarry, Boat Harbour and Health Care Activities Zones ...

(c) **AMEND** Rule 5.14.9.6.2 (v) as follows:

(v) Veranda fascia signs shall: ...

- be located not less than 0.5m from the kerbline of the road or 0.43m from the kerbline of the road adjoining the Beachlands Village Business Centre Zone.

(d) **AMEND** Rule 5.15.1 (d) as follows:

(d) canopies of entrances to buildings and verandahs attached to a retail premise, shop, service station or similar establishment may project over any yards;

(e) **AMEND** Rule 5.15.1 (g) as follows:

(g) signs may be erected on any yard in compliance with the Rules contained in Section 5.14.9 and / or any Zone.

(f) **AMEND** Rule 5.18.1.1 as follows:

All buildings in the Residential, Future Development, Rural, Business, Beachlands Village Business Centre, Flat Bush Town Centre and Flat Bush Neighbourhood Centre, Boat Harbour, Community Health Facility, Hospital, Community Health Support, Education, Papakainga and Maori Purposes Zones and Public Open Space Zones shall comply with the following: ...

(g) **AMEND** Rule 5.18.1.2 (b) as follows:

(b) Where a site adjoins a business zone, Beachlands Village Business Centre Zone and Flat Bush Town Centre and Flat Bush Neighbourhood Centre, Rule 5.18.1.1 shall not be applied to the common boundary.

(h) **AMEND** Rule 5.18.1.4 as follows:

Provided that in all Business zones (including the Beachlands Village Business Centre Zone) and Flat Bush Town Centre Zone and Flat Bush Neighbourhood Centre Zone

- (a) Rule 5.18.1.1 does not apply to the boundary between business zones (including the Beachlands Village Business Centre Zone) and Flat Bush Town Centre Zone and Flat Bush Neighbourhood Centre Zone.

- (i) **AMEND** Rule 5.18.1.5 as follows:

Provided that in Business 1, 2 ~~and~~, 3 and Beachlands Village Business Centre zones

- (a) Rule 5.18.1.1 (2) shall not apply.

9. Amendments to Chapter 9 – Land Modification, Development and Subdivision

Note: Amendments to text are shown as insertions underlined and deletions ~~struck through~~.

- (a) **AMEND** Rule 9.9.2.4 as follows:

Rule 9.9.2.4 Minimum Site Area of Allotments

- (a) **Residential and all Business Zones (including the Beachlands Village Business Centre Zone)**

- (b) **AMEND** Rule 9.9.2.10 (c) as follows:

- (c) **Access Standards – Business Zones (including the Beachlands Village Business Centre Zone)**

- (c) **ADD** the following bullet point to Rule 9.12.1 General Matters:

- Whether earthworks proposed to be undertaken within the Beachlands Village Business Centre Zone includes the provision of appropriate sediment control measures to ensure that any potential for impacts on the operation of the downstream stormwater management ponds are minimised as far as practicable.

- (d) **AMEND Appendix 2 Construction Standards for Roads** as follows:

Road Category	Type of Road	Minimum Width in Metres		Max. Grade	Road Function
		Road	Carriageway		
Secondary Network					
Local Roads	Private way serving 2–4 units	4.7	2.7	20%	Local Access

	Private way serving 5–15 units	6.5	4.5	20%	Local Access
	Service lane	5.0	4.5	10%	Local access for loading and unloading
	Cul de sac: serving up to 15 household units 12	12.0	5.4	12.5%	Local access, connects with local roads
	Cul de sac: serving 16 to 30 household units	14.6	5.4	12.5%	Local access, connects with local roads
	Local road (includes cul de sac serving more than 30 household units)	18.2	7.8	10%	Local access, not a bus route, connects with a through road Council may consider reducing carriageway width and it may require more than 7.8m around curves
	Business	23.6	12.2	5%	Access through business areas. Some serve as collector routes
	Beachlands Village Business Centre Roads	23.6	7.0*	10%	Access through the Beachlands Village Business Centre Zone
<p>Note: Business roads are those roads or portions of road that are continuously adjacent along one or both sides to business zoned land.</p>					

* Carriageway width may vary based on the final detailed design.

(e) **AMEND** Rule 9.8.2 – Activity Table as follows:-

ACTIVITY	CITY – WIDE EXCEPT FOR EXPLOSIVES ZONE AND WHITFORD LANDFILL ZONES
Landscaping features within roads or proposed roads provided as part of a subdivision and development except in the Beachlands Village Business Centre Zone.	(R)D

10. Chapter 18 - Definitions

Note: Amendments to text are shown as insertions underlined and deletions ~~struck through~~

- (a) **ADD** the following new definition

Mall

For the purposes of the Beachlands Village Business Centre, mall means a retail development within the Beachlands Village Business Centre Zone that is planned, built and managed as a single entity, comprising 5 or more retail units that do not have a customer entrance to a road or an open space plaza area, and:

- (a) with a total GFA of 2,000m² or greater (including unleased public space as lobby); and
- (b) which is located within an enclosed, roofed space that is mechanically ventilated.

